



# UFACTORY

## UFACTORY 850 Hardware Manual



SHENZHEN UFACTORY CO., LTD.

V 2.6.1

# Preface

Apply to Model: UFACTORY 850

## Joint Range:

Joint	Range	Joint	Range
J1	±360°	J4	±360°
J2	±132°	J5	±124°
J3	-242°~3.5°	J6	±360°

## Motion Parameters:

	TCP Motion	Joint Motion
Speed	0~1000mm/s	0 ~ 180°/s
Acceleration	0~50000mm/s <sup>2</sup>	0 ~ 1145°/s <sup>2</sup>
Jerk	0 ~ 100000mm/s <sup>3</sup>	0 ~ 28647°/s <sup>3</sup>

- In the TCP motion (Cartesian space motion) commands (set\_position function of the SDK), If a motion command involves both position transformation and attitude transformation, the attitude rotation speed is generally calculated automatically by the system. In this situation, the specified speed parameter is the maximum linear speed, range from: 0 ~ 1000mm/s.
- When the expected TCP motion only changes the attitude (roll, pitch, yaw), with position (x, y, z) remains unchanged, the specified speed is the attitude rotation speed, so the range 0 to 1000 corresponds to 0 to 180 °/s.

## Unit Definition:

Parameter	Python-SDK	Blockly	Communication Protocol
X (Y/Z)	millimeter (mm)	millimeter (mm)	millimeter (mm)
Roll (Pitch/Yaw)	degree (°)	degree (°)	radian (rad)
J1~J6	degree (°)	degree (°)	radian (rad)

Parameter	Python-SDK	Blockly	Communication Protocol
TCP Speed	mm/s	mm/s	mm/s
TCP Acceleration	mm/s <sup>2</sup>	mm/s <sup>2</sup>	mm/s <sup>2</sup>
TCP Jerk	mm/s <sup>3</sup>	mm/s <sup>3</sup>	mm/s <sup>3</sup>
Joint Speed	°/s	°/s	rad/s
Joint Acceleration	°/s <sup>2</sup>	°/s <sup>2</sup>	rad/s <sup>2</sup>
Joint Jerk	°/s <sup>3</sup>	°/s <sup>3</sup>	rad/s <sup>3</sup>

# 1. Safety

---

## 1.1 Validity and Responsibility

The information in this manual does not cover designing, installing, and operating of a complete robotic application system, nor does it cover all peripheral equipment that can influence the safety of the application. The complete system must be designed and installed under the safety requirements outlined in the standards and regulations of the country where the robotic arm is installed.

The integrators of UFACTORY 850 are responsible for the compliance of applicable safety laws and regulations in the country, to prevent any hazards in the operating environment. This includes, but is not limited to:





- Making a risk assessment for the complete system. Make sure to have a safe distance between people and 850 when interacting with the 850.
- Interfacing other machines and additional safety devices if defined by the risk assessment.
- For software programming, please read the interface documentations carefully and set up the appropriate safety functions in the software.
- Specifying instructions for use to prevent unnecessary property damage or personal injury caused by improper operation.

---

## 1.2 Limitation of Liability

Any safety information provided in this manual must be construed as a warranty by UFACTORY, that the 850 will not cause injury or damage even if all safety instructions are complied with.

---

Safety Alarms	
 <b>DANGER</b>	<p><b>DANGER</b></p> <p>This indicates an imminently hazardous electrical situation, which if not avoided, could result in death or serious damage to the device.</p>
 <b>WARNING</b>	<p><b>WARNING</b></p> <p>This indicates a potentially hazardous situation which, if not avoided, could result in death or serious damage to the device.</p>
 <b>HIGH TEMPERATURE</b>	<p><b>HIGH TEMPERATURE</b></p> <p>This indicates a potential hot surface, which if touched, could result in personal injury.</p>
 <b>NOTICE</b>	<p><b>NOTICE</b></p> <p>Failure to prevent this may lead to personal injury or equipment damage.</p>
 <b>CAUTION</b>	<p><b>CAUTION</b></p> <p>Failure to prevent this may lead to personal injury or equipment damage.</p>

## 1.3 General Warning and Cautions

This section contains some general warnings and cautions on installation and application planning for the robotic arm. To prevent damage to the machine and associated equipment, users need to learn all the relevant content and fully understand the safety precautions. We do not control or guarantee the relevance or completeness of such information in this manual, for which users should conduct self-assessment of their specific problems.

### **DANGER**

- Make sure to use the correct installation settings in this manual for the robotic arm and all the electrical equipment.

- Please follow the instructions in this manual, installation, and commissioning needs to be performed by professionals in accordance
- Make sure the robotic arm and tool are properly and securely bolted in place.
- The integrity of the device and system must be checked before each use (e. g. the operational safety and the possible damage of the robotic arm and other device systems).
- Preliminary testing and inspection for both robotic arm and peripheral protection system before production is essential.
- The operator must be trained to guarantee a correct operation procedure when using SDK(Python/ROS/C++) and graphical interface UFactory studio.
- A complete safety assessment must be recorded each time the robotic arm is re-installed and debugged.
- When the robotic arm is in an accident or abnormal operation, the emergency stop switch needs to be pressed down to stop the movement, and the posture of the robotic arm will slightly brake and fall.
- The 850 joint module has brakes inside, which will remain manipulator's pose when a power outage occurs.
- When the robotic arm is in operation, make sure no people or other equipment are in the working area.
- When releasing the brakes of 850, please take protective measures to prevent the robotic arm or operator from damage or injury.
- When connecting the 850 with other machinery, it may increase risk and result in dangerous consequences. Make sure a consistent and complete safety assessment is conducted for the installation system.

## **HIGH TEMPERATURE**

- The robotic arm and Control Box will generate heat during operation. Do not handle or touch the robotic arm and Control Box while in operation or immediately after the operation.
- Never stick fingers to the connector of the end-effector.

## **CAUTION**

- Make sure the robotic arm's joints and tools are installed properly and safely, and check the status for all circuits.
- Make sure that there is enough space for the manipulator to move freely.
- Make sure that there is no obstacle in the robotic arm's working space.

- The Control Box must be placed outside the working range of the robotic arm to ensure the emergency stop button can be pressed once an emergency occurs.
- If the robotic arm is in operation and needs an emergency stop, make sure the restart/reset motions will not collide with any obstacle.
- Do not modify the robotic arm (or Control Box). Any modification may lead to unpredictable danger to the integrators. The authorized restructuring needs to be in accordance with the latest version of all relevant service manuals. If the robotic arm is modified or altered in any way, UFACTORY (Shenzhen) Technology Co., Ltd. disclaims all liability.
- Users need to check the collision protection and water-proof measures before any transportation.

## NOTICE

- When the 850 cooperates with other machinery, a comprehensive safety assessment of the entire collaboration system should be performed. It is recommended that any equipment that may cause mechanical damage to 850 be placed outside the working range during application planning.

---

## 1.4 Personnel Safety

When operating or running robots, the foremost priority must be to ensure the safety of operating personnel. General precautions are listed below. Please properly implement corresponding measures to guarantee the safety of personnel involved in the operation.

### CAUTION

- Each operator who uses the robotic arm system should read the product user manual carefully. Users should fully understand the standardized operating procedures with the robotic arm, and the solution to the robotic arm running error.
  - When the device is running, even if the robotic arm seems to stop, the robotic arm may be waiting for the signal and in the upcoming action status. Even in such a state, it should be considered as the robotic arm is in action.
  - A line should be drawn to mark the range of motion of the robotic arm to let the operator acknowledge the robotic arm, including its end tools (such as gripper and suction cup, etc) operating range.
  - Check the robotic arm regularly to prevent loosening of the bolts that may cause undesirable consequences.
-

- Be careful when the robotic arm is running too fast.
- Be careful about dropping items that can be caused by accidental power off or unstable clamping of the robotic arm.

### **WARNING**

- Do not alter any information in the controller safety configuration. If parameters in the configuration file are modified, the entire robot system shall be deemed a new system, which necessitates the update of all safety review processes, such as risk assessments.
- Replace faulty components only with new parts of the same part number or UFACTORY-approved equivalent components.
- Document all maintenance operations in writing and retain these records within the technical documentation associated with the entire robot system.

### **DANGER**

- Remove the main power cable from the controller to ensure complete power disconnection. Take necessary precautions to prevent unauthorized re-energization of the system by others during maintenance.
  - Before restarting the system, ensure that grounding connections are verified.
  - Comply with ESD (Electrostatic Discharge) regulations when disassembling the mechanical arm or controller.
  - Avoid disassembling the power supply system within the controller. The power supply system may retain high voltage for several hours after the controller is shut down.
  - Prevent the ingress of water or dust into the mechanical arm or controller.
-

## 2. Hardware Installation

### 2.1 Hardware Composition

#### 2.1.1 Hardware Composition

The composition of robotic arm hardware includes:

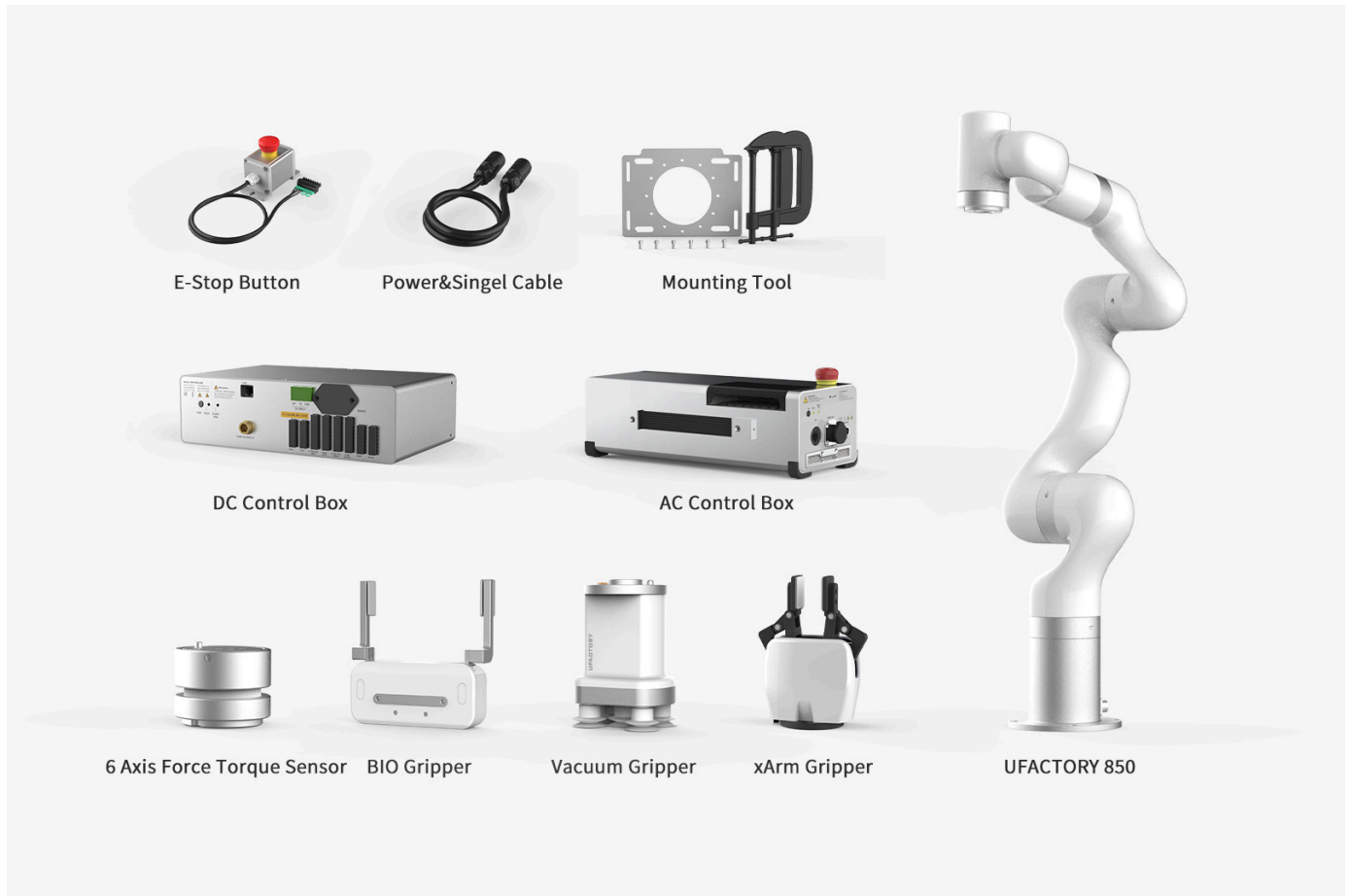

- UFACTORY 850 Robotic Arm
- AC Controller
- DC Controller
- 850 Power and Signal cable
- Mounting Tool
- End Effector(Gripper, Vacuum Gripper, BIO Gripper G2, FT Sensor)

The 850 Robotic Arm system consists of a base and rotary joints, and each joint represents a degree of freedom. From the bottom to the top, in order, Joint 1, Joint 2, Joint 3, etc. The

last joint is known as the tool side and can be used to connect end-effector (e. g. gripper, vacuum gripper, etc).

## 2.1.2 Emergency Stop Button

By pressing the emergency stop button of the Control Box, a command will be sent to the Control Box for software deceleration to stop all activities of the robotic arm and clear all the cached commands in the Control Box; the power supply for the robotic arm will be removed within 300ms. The emergency stop should not be used as a risk reduction measure. When an emergency occurs during the operation of the robotic arm, users need to press the emergency stop, and the posture of the robotic arm will slightly brake and fall. The emergency stop button is shown below:

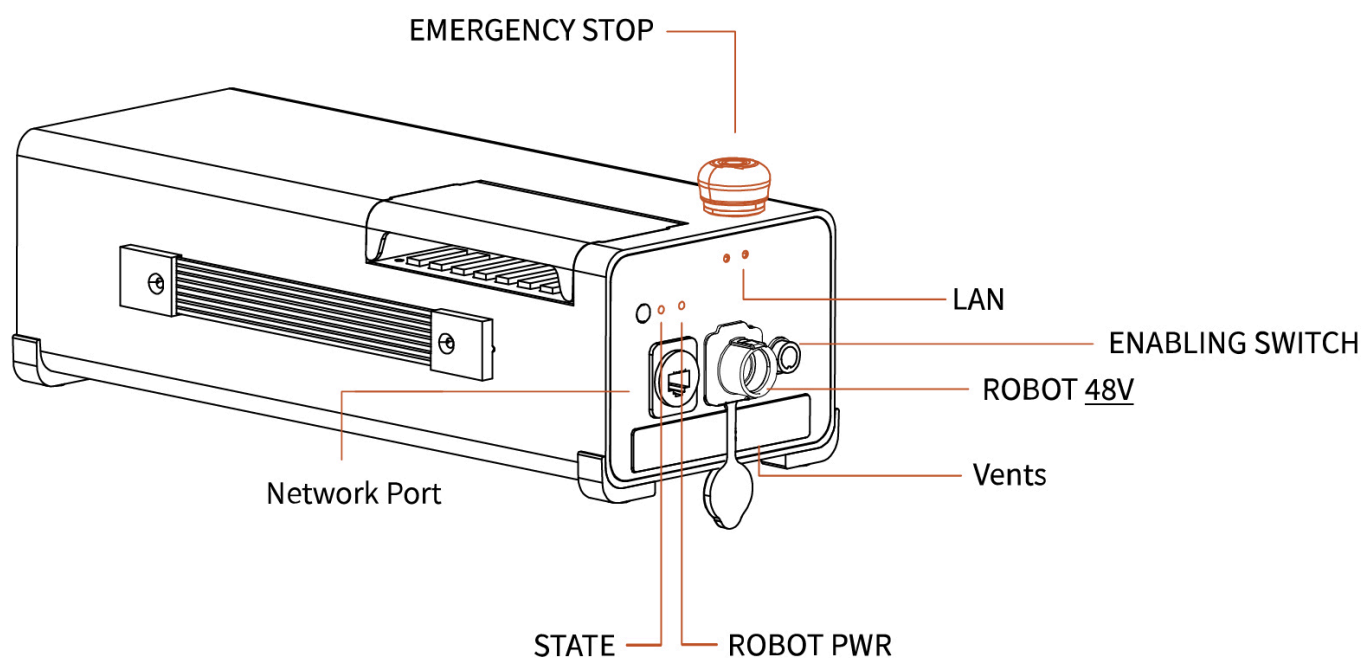

Indicator	Label	Function
ROBOT Power	ROBOT PWR	ON - The 850 is powered on.
Controller Power Status	STATE	Flash - The controller is powered on.
Network Port	LAN	ON - The 850 is communicating normally.

### Emergency Stop

Press the emergency stop button to power off the 850, and the power indicator will go out.

### Power-on

when the button is rotated in the direction indicated by the arrow, the button is pulled up, the 850 power indicator lights up, and the arm is powered.

After pressing the emergency stop button, the following operations should be performed to re-start the 850:

- Power up the 850 (Turn the emergency stop button in the direction of the arrow).
- Enable the 850 (enable the servo motor), Enable button on the UFACTOR Studio or Python SDK `motion_enable(true)` .

---

## 2.2 UF850 Installation

### 2.2.1 Safety Guidelines

#### DANGER

- Make sure the arm is properly and safely installed in place. The mounting surface must be shockproof and sturdy.
- To install the arm body, check that the bolts are tight.
- The robotic arm should be installed on a sturdy surface that is sufficient to withstand at least 10 times the full torsion of the base joint and at least 5 times the weight of the arm.

#### WARNING

- The robotic arm and its hardware composition must not be in direct contact with the liquid, and should not be placed in a humid environment for a long time.
- A safety assessment is required each time installed.
- When connecting or disconnecting the arm cable, make sure that the external AC is disconnected. To avoid any electric shock hazard, do not connect or disconnect the robotic arm cable when the robotic arm is connecting with external AC.

### 2.2.2 Define Working Space

The robotic arm workspace refers to the area within the extension of the links. The figure below shows the dimensions and working range of the robotic arm. When installing the robotic arm, make sure the range of motion of the robotic arm is taken into account, so as not to bump into the surrounding people and equipment (the end-effector not included in the working range).

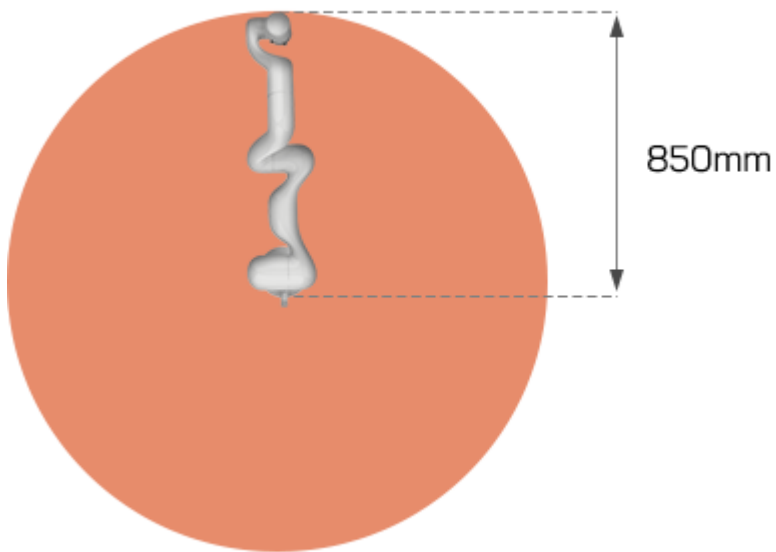
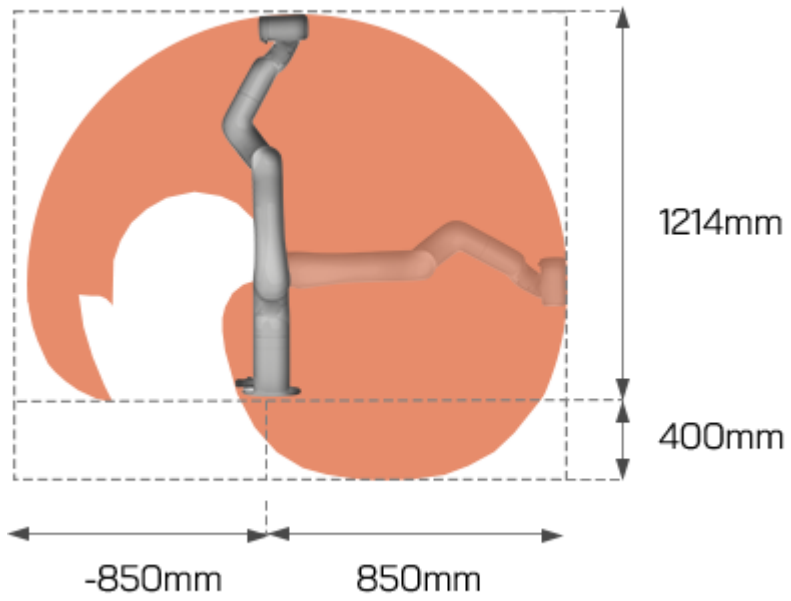

## 2.2.3 Installation

Brief installation steps:

1. Define Working Space.
2. Fix the robotic arm base.
3. Connect the robotic arm with the controller.
4. Connect the controller with cable.

## 5. Install End-Effector.

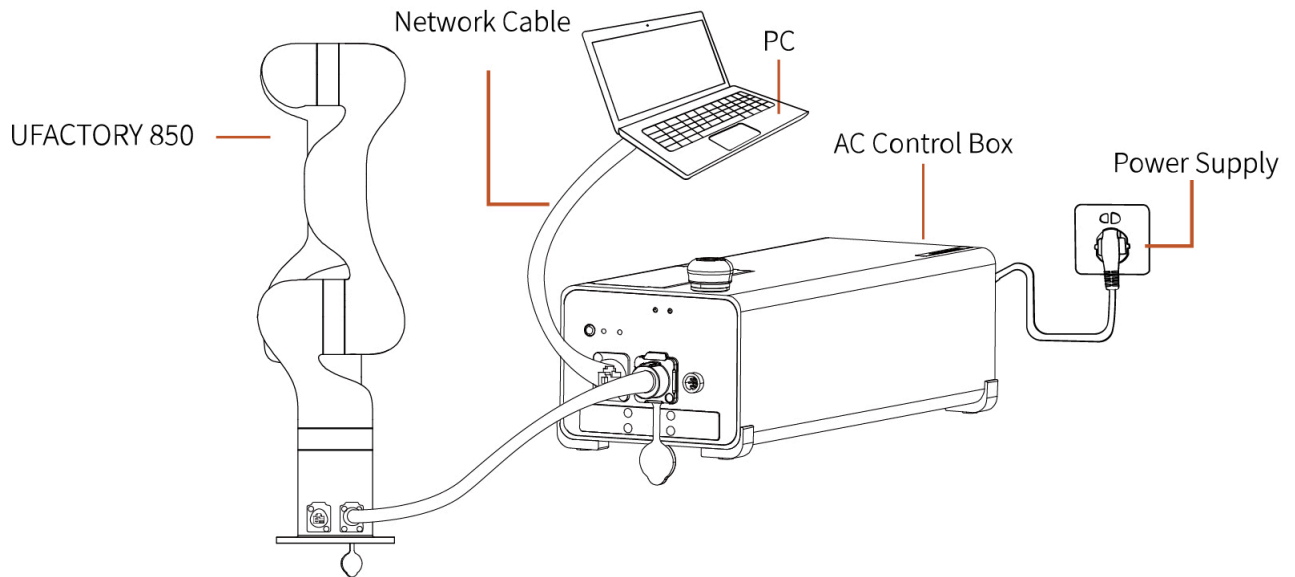

### 2.2.3.1 Robot Base Mounting

The robotic arm has four M8 bolts provided and can be mounted through four  $\text{Ø}8.5$  holes in the base of the robotic arm. It is recommended to tighten these bolts with a torque of 20Nm.

Unit: mm

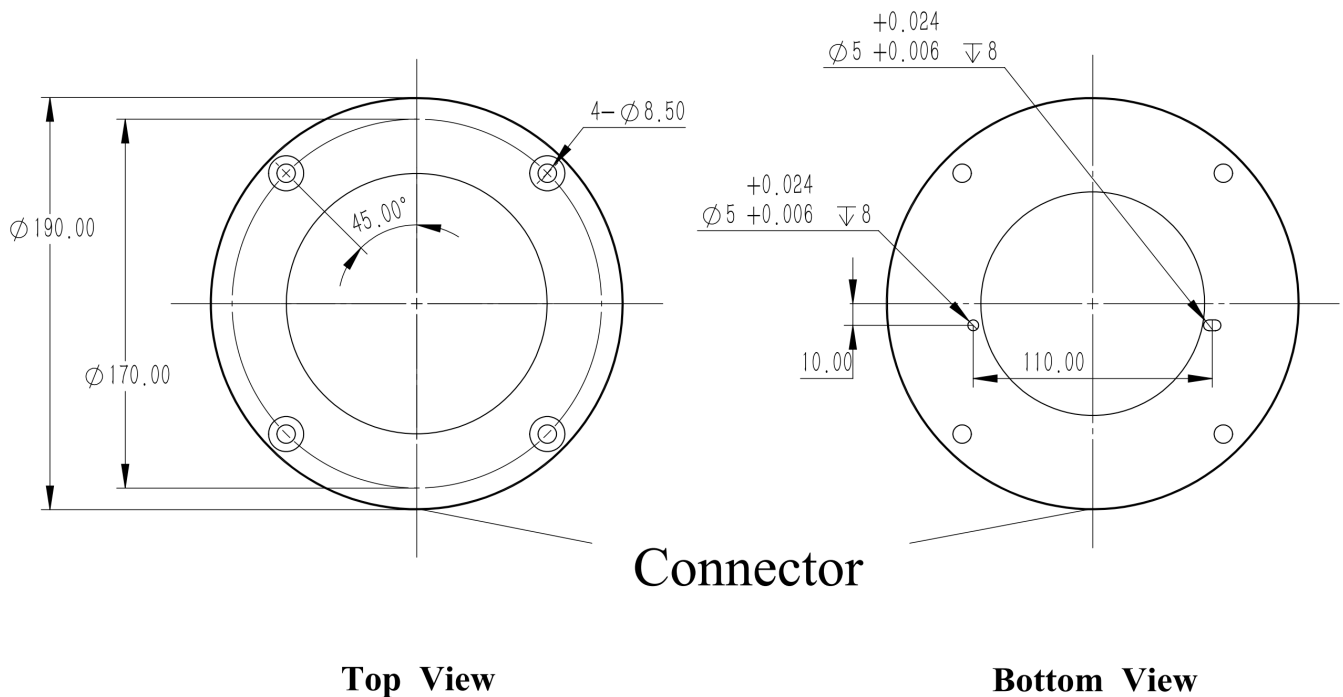

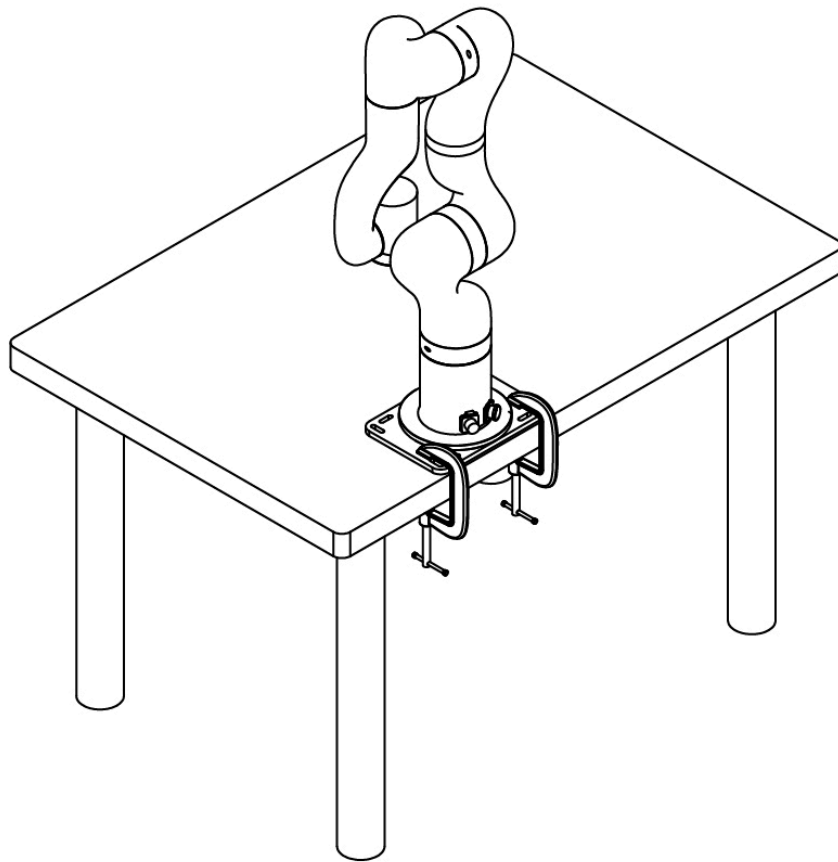

### 2.2.3.2 Connect with Controller

1. Plug the connector of the Robotic Arm Power Supply Cable and the Robotic Arm Signal Cable into the interface of the Robotic Arm. The connector is a foolproof design. Please do not unplug and plug it violently.
2. Plug the Robotic Arm Power Supply Cable and the Robotic Arm Signal Cable into the Control Box.
3. Plug the Control Box Power Cable into the AC (110V-240V) interface on the Control Box and the other end into the socket (as shown in Figure below).

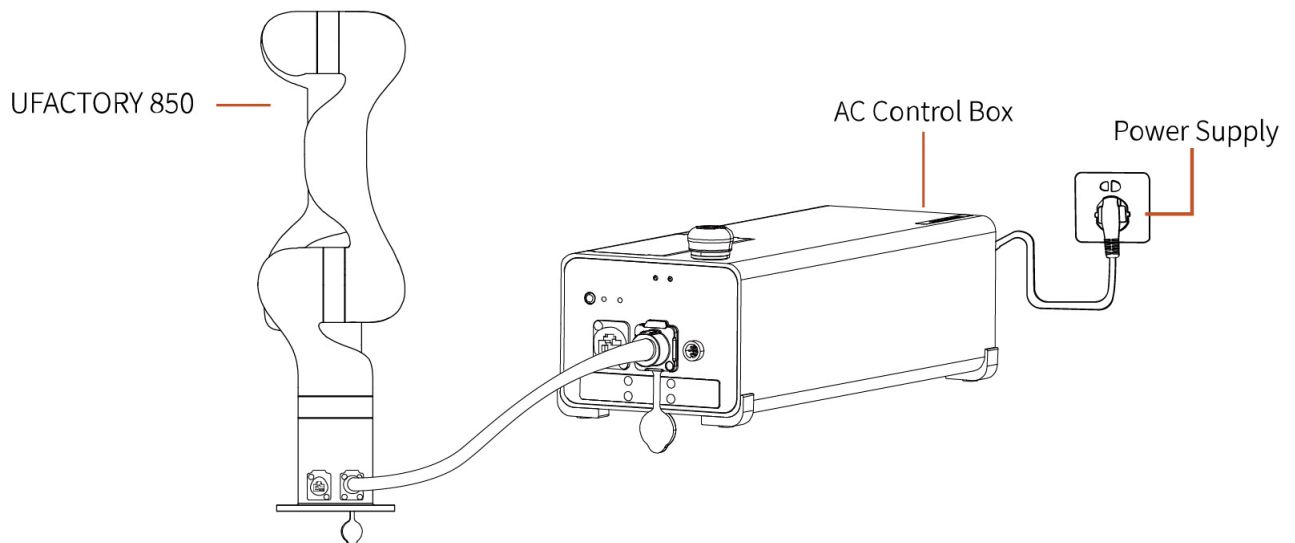

### 2.2.3.3 Controller Networking

There are four ways of network settings for the robotic arm. You can choose the appropriate network setting method according to your scenario.

1. The control box is directly connected to the PC(Recommended connection method).

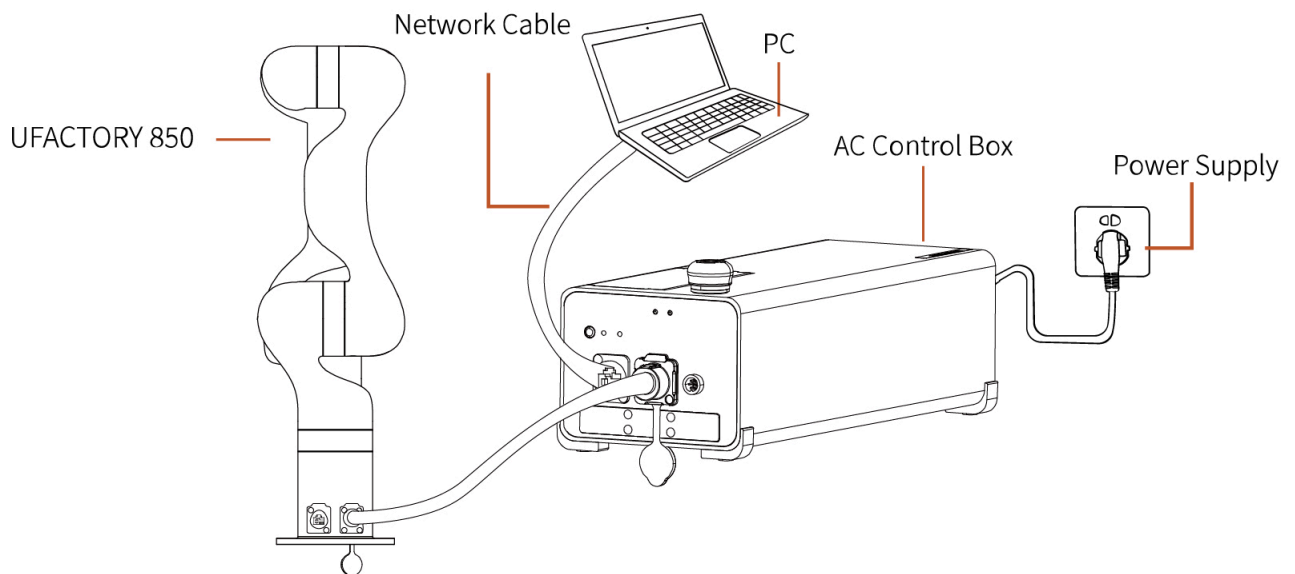

2. The control box, PC and router are connected by Ethernet cable.

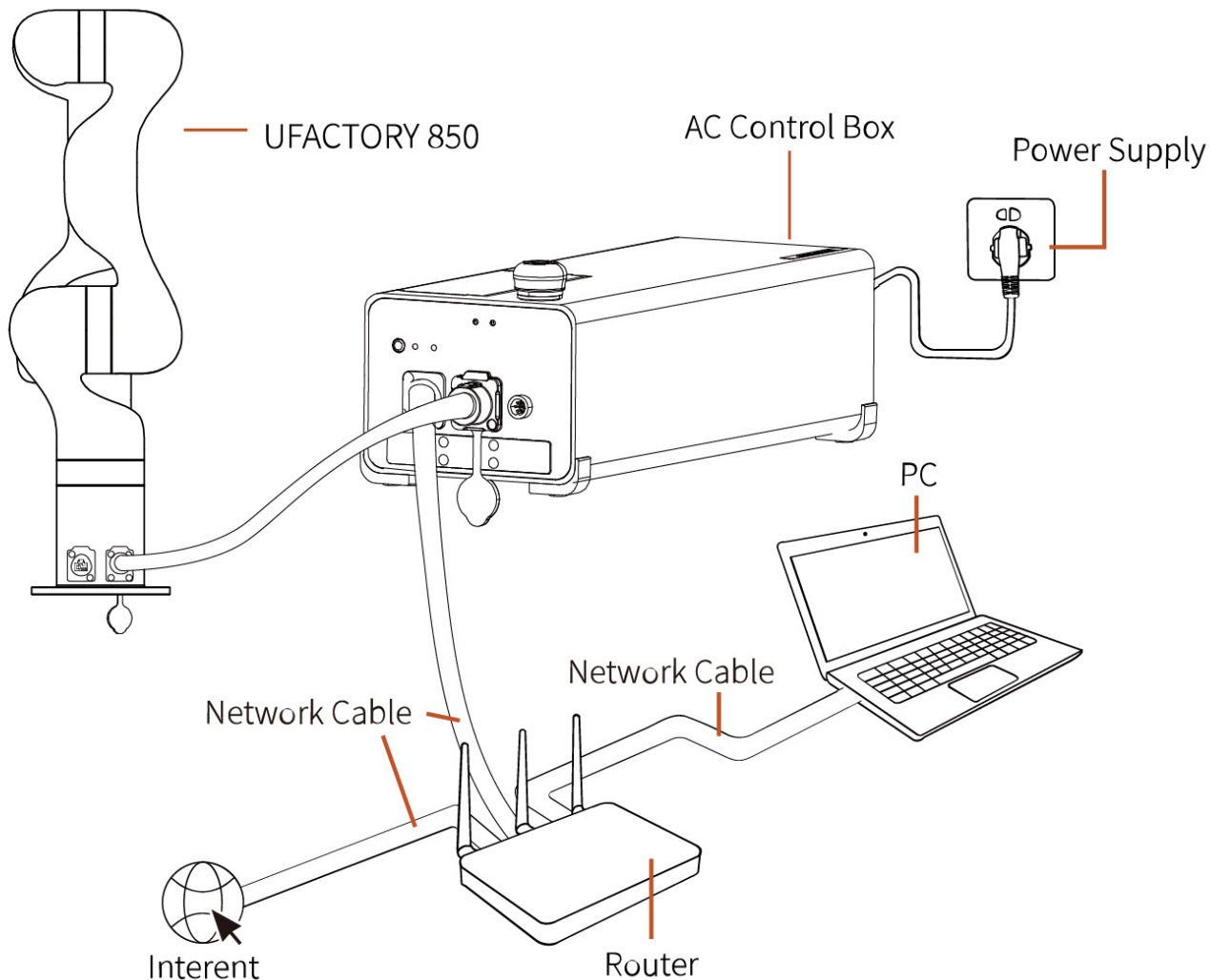

3. PC and router are connected by wireless network, and control box and router are connected by Ethernet cable. **Note:** It is not recommended because of the delay and packet loss of wireless connection.

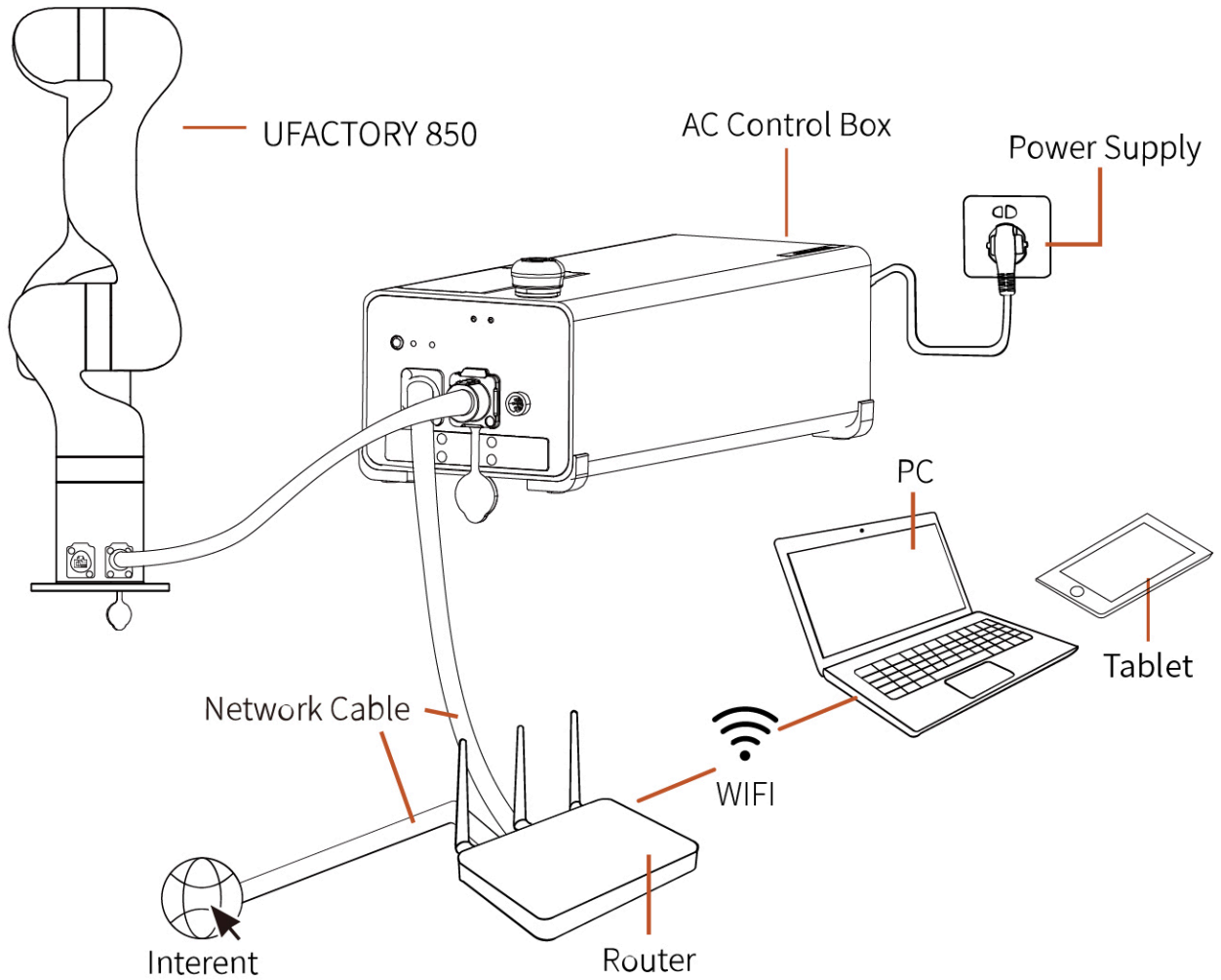

4. The control box, PC and network switch are connected by Ethernet cable.

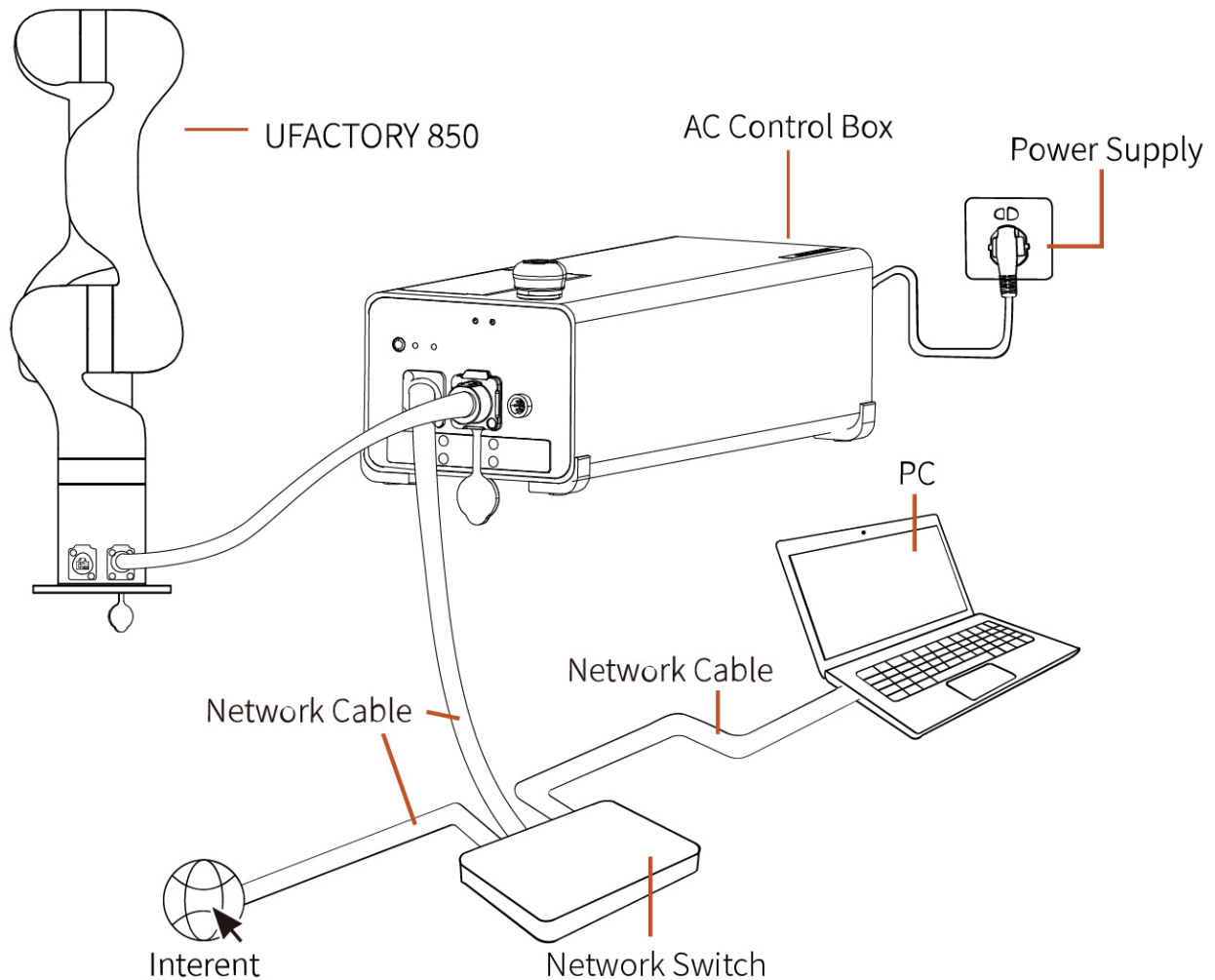

## 2.3 Power Supply for 850

- Ensure the power cable and the communication wire are properly connected between the Control Box and the robotic arm.
- Ensure the network cable or RS-485 cable is properly connected.
- Ensure the power cable for the Control Box is properly connected.
- Ensure the 850 will not hit any personnel or equipment within the working range.

### 2.3.1 Power On

1. Turn on the OFF/ON button and ensure the indicator lights are lit.
2. Press the power button, when the status indicator (CONTROLLER) lights up, the control box is turned on.
3. Rotate the emergency stop button in the direction indicated by the arrow and is pulled up, at which point the 850 power indicator (ROBOT PWR) lights up.

4. Use the UFactory studio / SDK command to complete the operation of enabling the robotic arm. (enable the servo motor)

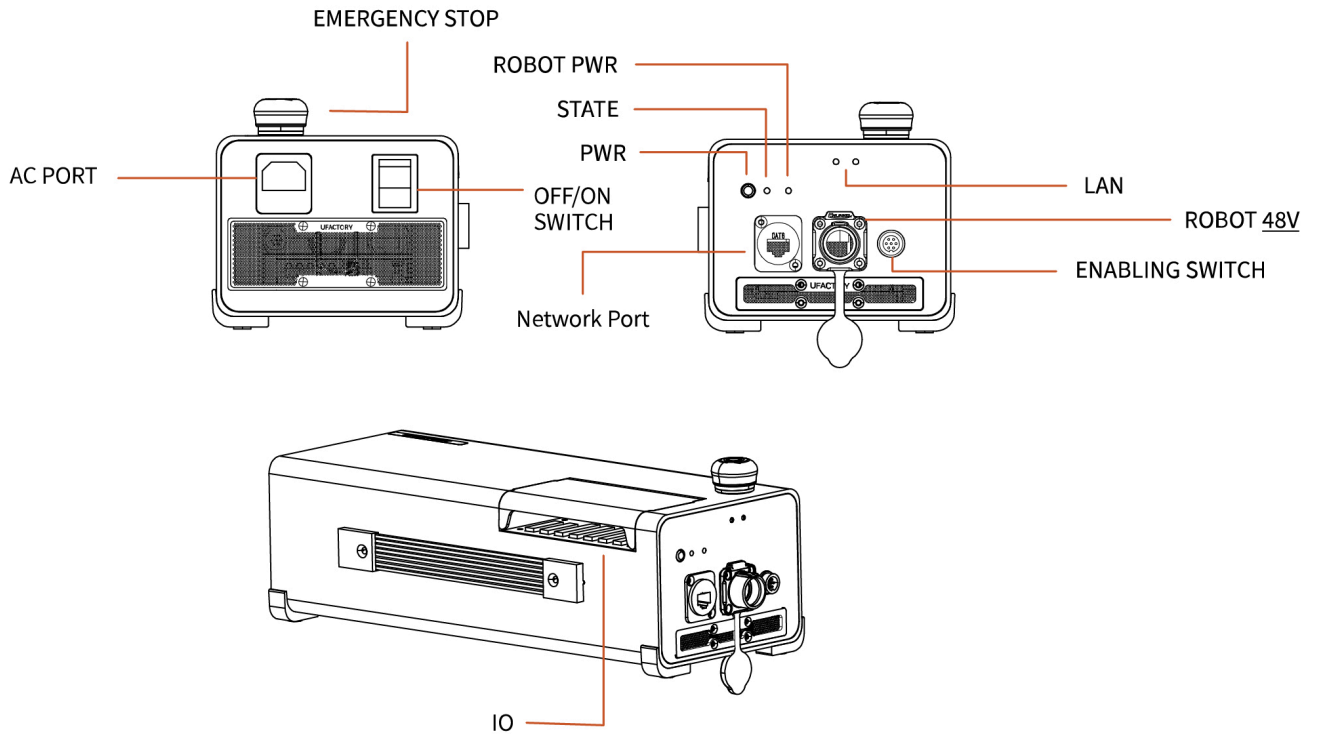

### 2.3.2 Shut Down



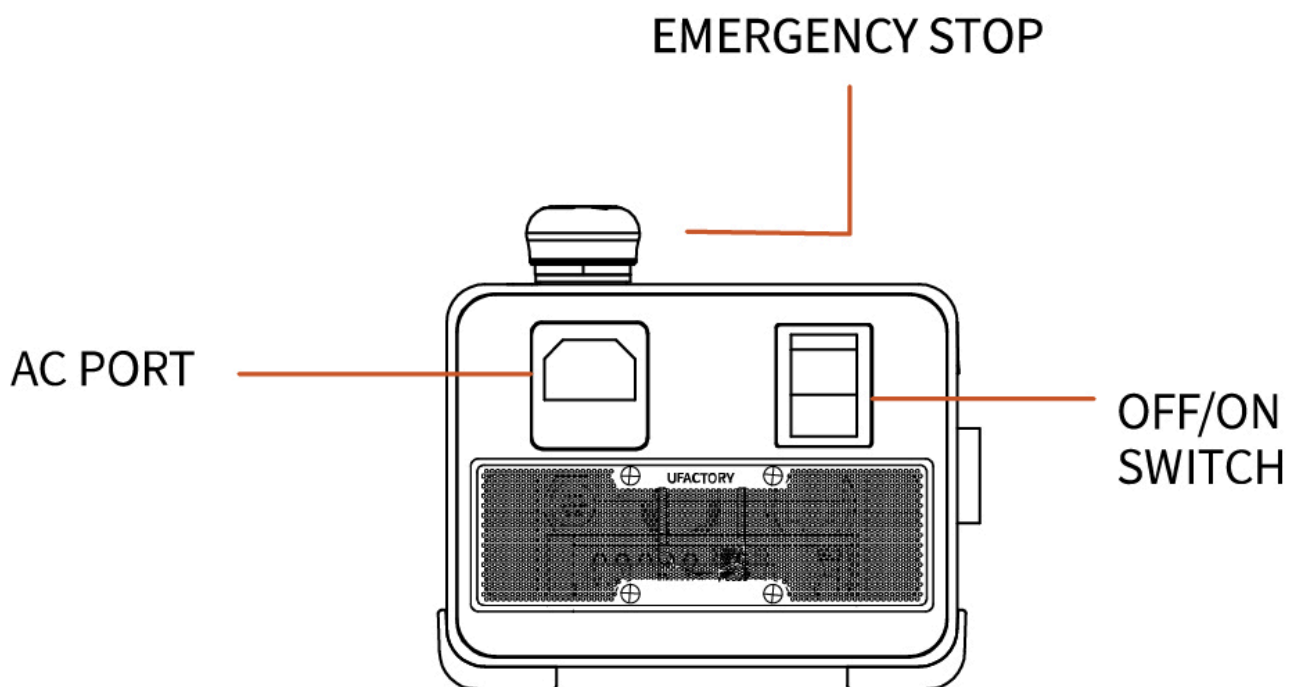

1. Press the EMERGENCY STOP button to power off the robotic arm, ensure the power indicator light is off.
2. Turn off the power supply of the control box (The power switch takes about 5 seconds to turn off the power of the control box. Please do not restart the control box within 5 seconds after turning off the power supply).



## 3. Controller Electrical Interface

### 3.1 Electrical Alarms and Cautions

Always follow the warnings and cautions below when designing and installing a robotic arm application. These warnings and cautions are also subject to the implementation of maintenance work.

ICON	
 NOTICE	<ol style="list-style-type: none"> <li>1. Make sure that all the non-waterproof equipment is kept dry. If water enters the product, turn off the power supply, and contact your supplier.</li> <li>2. Use only the original cable of the robotic arm. Do not use the robotic arm in applications where the cable needs to be bent. If you need a longer cable or flexible cable, please contact your supplier.</li> <li>3. All GND connectors mentioned in this manual are only suitable for powering and transmitting signals.</li> <li>4. Be careful when installing the interface cable to the I/O of the robotic arm.</li> </ol>
 CAUTION	<ol style="list-style-type: none"> <li>1. Interfering signals above the level specified in the IEC standard will cause abnormal behaviour of the robotic arm. Extremely high signal levels or excessive exposure can cause permanent damage to the robotic arm. UFACTORY (Shenzhen) Technology Co., Ltd. is not responsible for any loss caused by EMC problems.</li> <li>2. The length of the I/O cable that used to connect the Control Box with other mechanical and plant equipment must not exceed 30 meters unless it is feasible after the extension testing.</li> </ol>
 WARNING	<p>When wiring the electrical interface of the Control Box, the Control Box must be powered off.</p>
 DANGER	<p>Never connect a safety signal to a non-safety PLC. Failure to follow this warning may result in serious injury or death due to an invalid safety stop function.</p>

### 3.2 AC Controller

#### 3.2.1 Hardware Connector

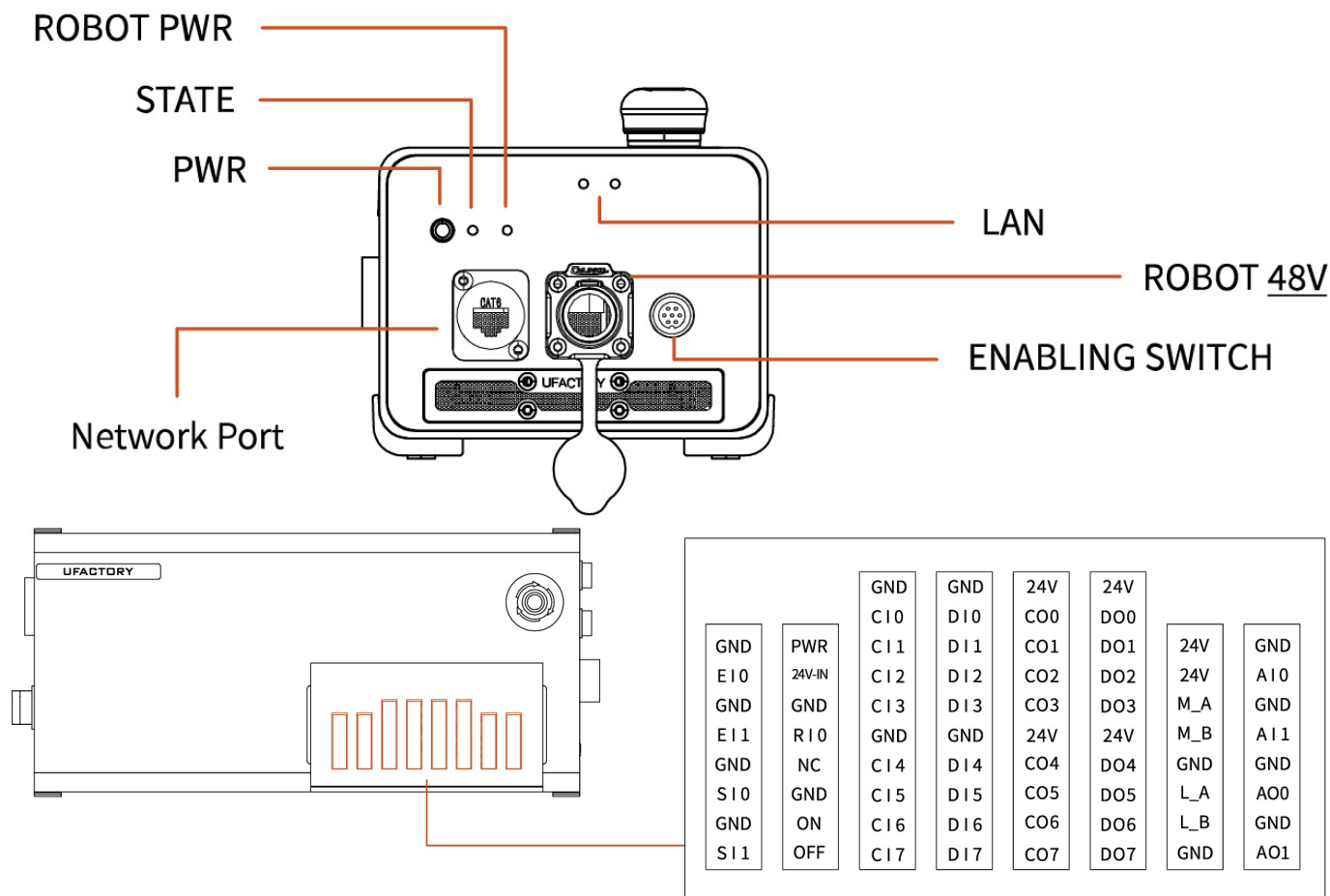

### 3.2.2 Power Supply

There is a standard IEC plug at the end of the control box's main cable.

Connect a local dedicated main outlet or cable to the IEC plug. The control box is powered by 100V-240V AC (the input frequency is 47-63HZ) and its internal switching power supply converts 100V-240V AC into 12V, 48V DC, which supplies power to the load of the control box and the robotic arm.

Therefore, it is necessary to check whether the connection between the robotic arm and the control box is secured before use. The hardware protection and software protection of the control box can ensure the safety of use largely. The emergency stop button of the control box allows the user to cut off the power of the robotic arm in the shortest time possible and protect the safety of both personnel and the equipment.

To power on the robotic arm, the control box must be connected to the power supply. In this process, the corresponding IEC C19 wire must be used.

Connect to the standard IEC C20 plug of the Control Box to complete the process, see the figure below.

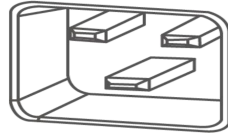

### 3.2.3 Definition of Industrial Connector

Power and Signal Cable:

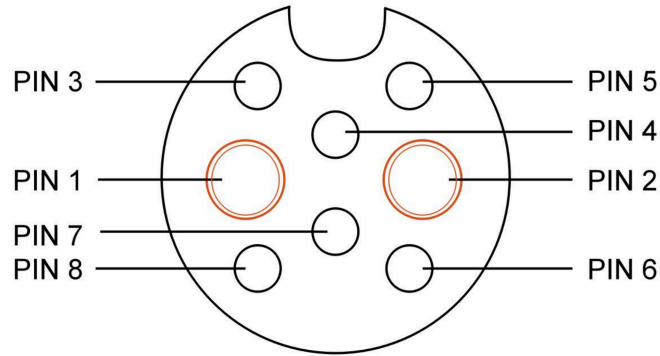

8-Pin Industrial Connector			
1	48V	5	RS485-B, Green-White, Arm
2	GND	6	RS485-B, Blue-White, Tool
3	RS485-A, Green, Arm	7	Shield
4	Shield	8	RS485-A, Blue, Tool

## 3.3 DC Controller

### 3.3.1 Hardware Connector

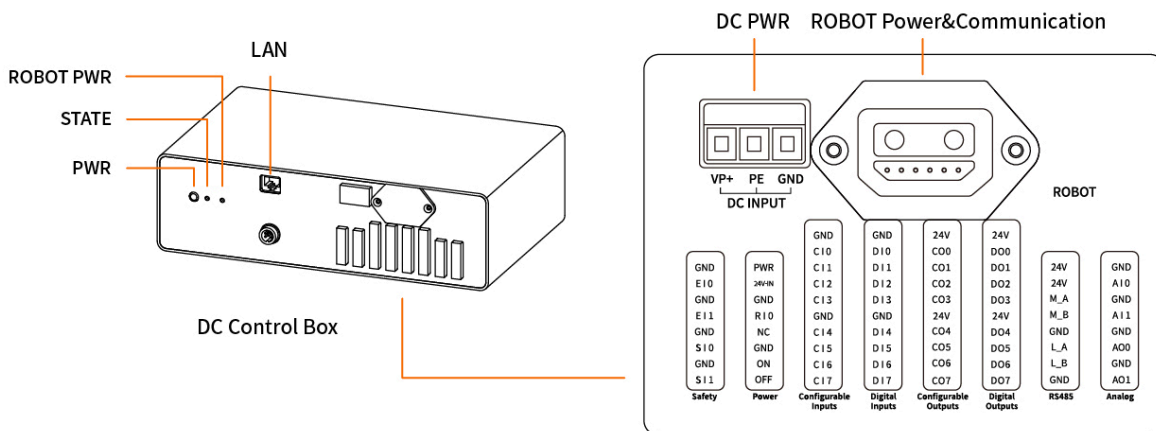

**ROBOT PWR:** The power of robotic arm, it will be RED after enabling the robotic arm.

**STATE:** The state of controller, it will be GREEN after powering on the controller.

**PWR:** For internal debug only.

**LAN:** Left light flashing, right light on.

**Connection** It will come with a Robot Pwr&Communication Adapter Cable, please connect as below.

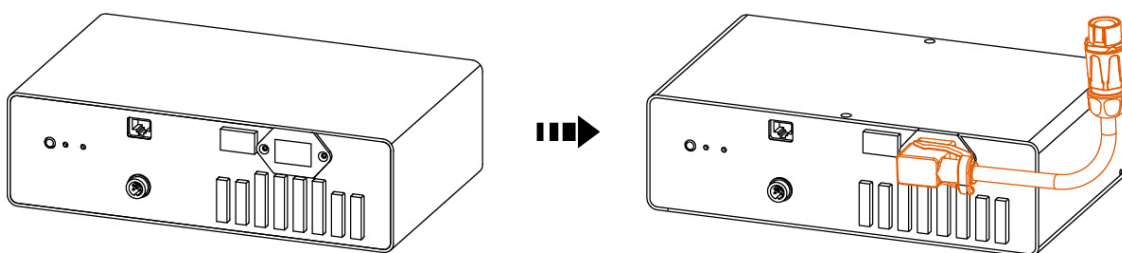

### 3.3.2 Power Supply

DC8500 Input Power	
VP+	48-72V
PE	Connect to the controller housing(Leakage Protection), not a must
GND	GND
Output	48VDC 960Wmax

**NOTE**

Insufficient input power may result in joint undervoltage conditions, arm enablement failure, communication breakdown, and cyclic controller reboots.

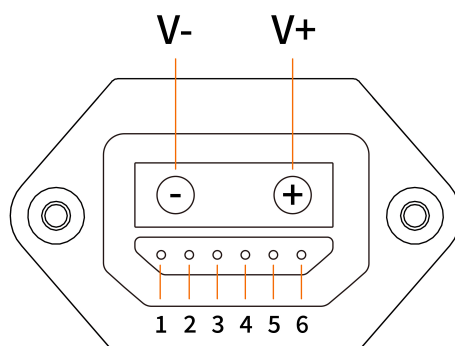
**3.3.3 Definition of Industrial Connector**

Robot Power and Signal Cable:

PIN	Functional Definition	PIN	Functional Definition
V+	48V	V-	GND
PIN1	RS485-A, Arm	PIN2	RS485-B, Arm
PIN3	PE	PIN4	PE
PIN5	RS485-A, Tool	PIN6	RS485-B, Tool

**3.4 Controller Electrical IO**

This chapter explains how to connect devices to the electrical I/O outside of the control box.

The I/Os are extremely flexible and can be used in many different devices, including pneumatic relays, PLCs, and emergency stop buttons.

The figure below shows the electrical interface layout inside the control box.



Configurable IO:

Configurable Function	CI0-CI7	DI0-DI7
General Input	Yes	Yes
Stop Moving	Yes	No
Safeguard Reset	Yes	No
Offline Task	Yes	Yes
Manual Mode	Yes	Yes
Reduced Mode	Yes	No
Enable Robot	Yes	Yes

Configurable Function	CO0-CO7	DO0-DO7
General Output	Yes	Yes
Motion Stopped	Yes	Yes
Robot Moving	Yes	Yes
Error	Yes	Yes
Warning	Yes	Yes
Collision	Yes	Yes
Manual Mode	Yes	Yes
Reduced Mode	Yes	Yes

Configurable Function	CO0-CO7	DO0-DO7
Offline Task Running	Yes	Yes
Robot Enabled	Yes	Yes
Emergency Stop is Pressed	Yes	Yes

It is very important to install 850 according to the electrical specifications.

All the I/O must comply with the specifications. The digital I/O can be powered by a internal 24V power supply or by an external power supply by configuring the power junction box. In the following figure, PWR is the internal 24V power output. The lower terminal (24V-IN) is the 24V input external power input for I/O. The default configuration is to use internal power, see below.

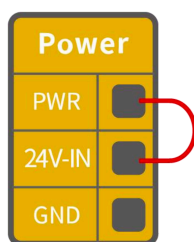

If larger current is needed, connect the external power supply as shown below.

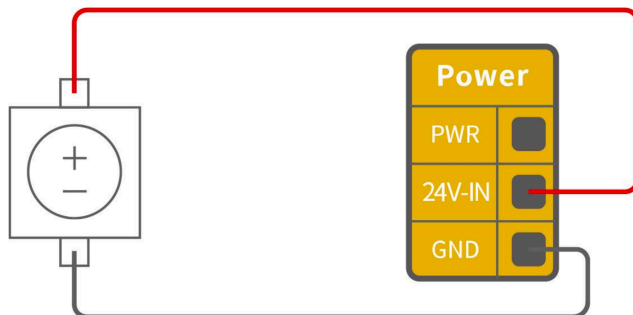

The electrical specifications for the internal and external power supplies are as follows.

Terminal	Parameter	Min. Value	Typical Value	Max. Value	Unit
Built-in 24V Power Supply					
[PWR - GND]	Voltage	23	24	30	V
[PWR - GND]	Current	0	-	1.8	A
External 24V Input Requirement					

Terminal	Parameter	Min. Value	Typical Value	Max. Value	Unit
[24V - 0V]	Voltage	20	24	30	V
[24V - 0V]	Current	0	-	3	A

The digital I/O electrical specifications are as follows(For resistive or inductive loads up to 1H).

Terminal	Parameter	Min. Value	Typical Value	Max. Value	Unit
Digital Output					
[COx]	Current	0	-	100	mA
[COx]	Voltage Goes Down	0	-	0.5	V
[COx]	Open Drain Current	0	-	0.1	mA
[COx]	Function	-	NPN (OC)	-	Type
Digital Input					
[EIx/SIx/CIx/RIx]	Voltage	0	-	30	V
[EIx/SIx/CIx/RIx]	OFF Area	15	-	30	V
[EIx/SIx/CIx/RIx]	ON Area(low level)	0	-	5	V
[EIx/SIx/CIx/RIx]	Current (0-0.5)	3	-	8	mA
[EIx/SIx/CIx/RIx]	Function	-	-	-	Type

### CAUTION

There is no current protection on the digital output of the Control Box. If the specified values exceeded, permanent damage may result.

### 3.4.1 Safety IO(EISI)

All safety I/Os exist in pairs (redundancy) and must be kept in two separate branches. A single I/O failure should not result in the loss of safety features. There are two fixed safety inputs:

- The robotic arm emergency stop input is only used for the emergency stop of the device.
- The protective stop input is used for all types of safety protection.

The functional differences are as follows.

	Emergency Stop	Protective Stop
Stops the motion of the robotic arm	Yes	Yes
Program execution	Stop	Suspend
Reset	Manual	Auto or manual
Usage frequency	Not frequent	No limit
Need re-initiation	Only releasing the brake	No

The robotic arm has been configured by default and can be operated without any additional safety equipment, as the figure below. If there is a problem with the robotic arm, please check the following figure for the correct connection.

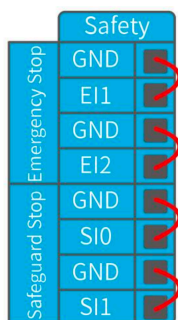

### 3.4.1.1 Connect to Emergency Stop Button

Digital IO: E1, E2, SI0, SI1.

In most applications, one or more additional emergency stop buttons are required. The figure below shows how to connect one or more emergency stop buttons.

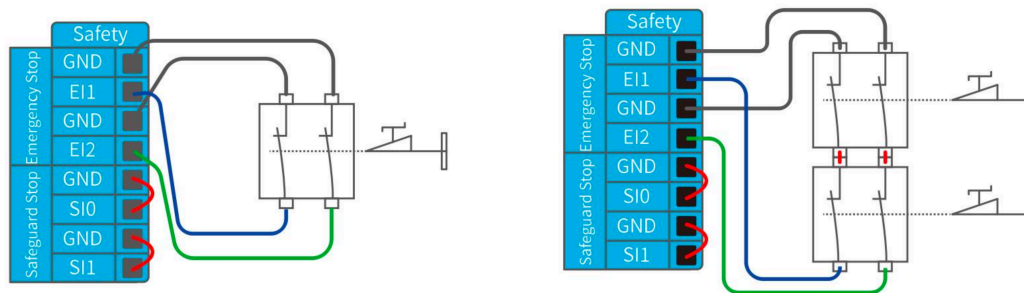

### 3.4.1.2 Share Emergency Stop with other Machines

Digital IO: E11, E12, SI0, SI1.

When a robotic arm is used with other machines, it requires to set up a common emergency stop circuit in most of the time. The following figure shows that two robotic arms share an emergency stop button (the connection method shown in the figure below also applies to multiple robotic arms sharing an emergency stop button).

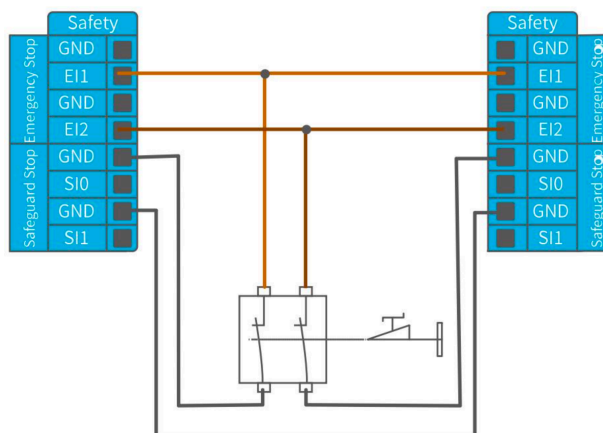

### 3.4.1.3 Automatically Recoverable Protective Stop

The door switch is an example of a basic protective stop device. When the door is open, the robotic arm stops. See the figure below.

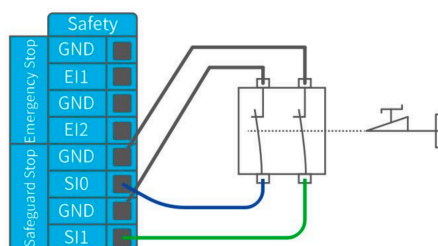

This configuration is only for applications where the operator is unable to close the door from behind. Configurable I/O can be used to set the reset button outside the door, as to reactivate the movement of the robotic arm. Another example of an automatic recovery is the use of a safety pad or a safety laser scanner, see the figure below.

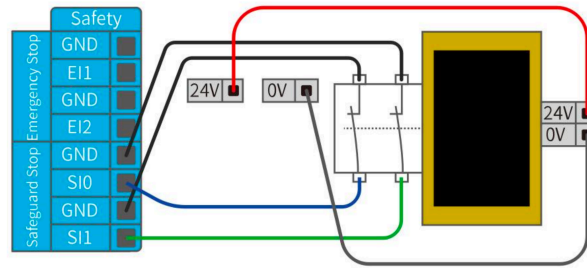

### 3.4.1.4 Protective Stop with Rest Button

If you use a protective interface to interact with the light curtain, you need to reset from outside the safety zone. The reset button must be a two-channel button. In the example shown below, the I/O of the reset configuration is CI0 (the corresponding configuration must also be done in UFactory Studio).

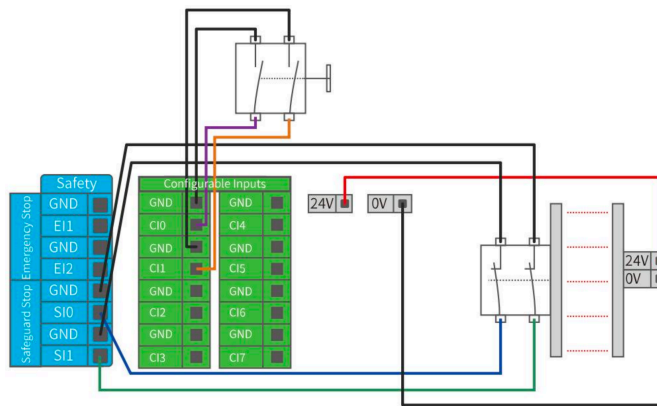

How to realize the protection reset function with reset button:

1. Configure "CI0" as the safeguard reset in UFactory studio. The specific steps are as follows: Enter 'Settings - External - Controller IO - IO Function', set CI0 as safeguard reset and save.

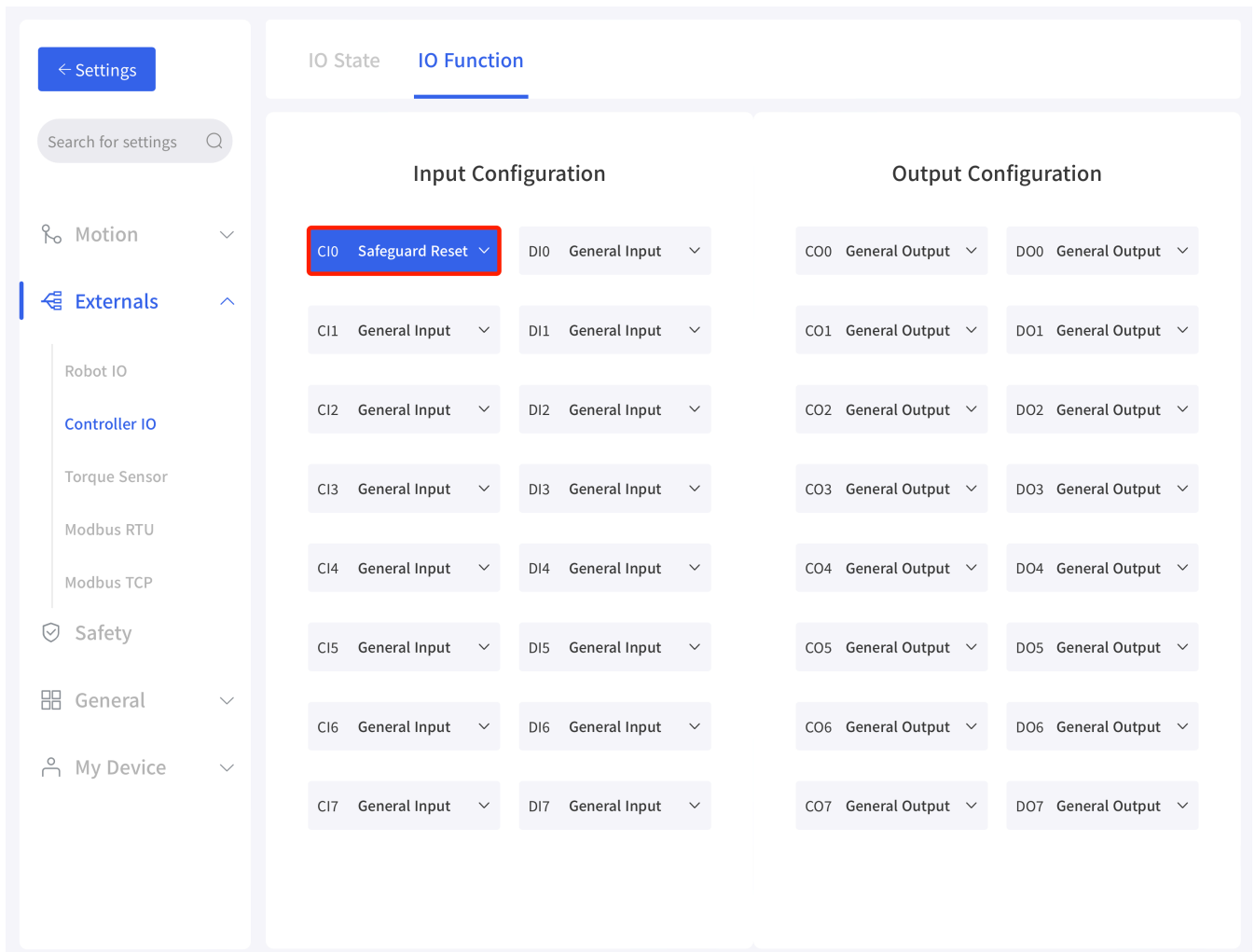

2. If 850 needs to resume motion, connect SI0 and SI1 to GND, and trigger the motion of 850 by connecting CI0 to GND; if 850 needs to pause the motion, disconnect SI0 and SI1 from GND.

**NOTE** DI0-DI7 are not equipped with the following three functions: stop moving, safeguard reset, and reduced mode.

## 3.4.2 Controller Digital Input&Output(CICO)

### 3.4.2.1 Controller Digital Input(CI)

The digital input is implemented in the form of a weak pull-up resistor. This means that the reading of the floating input is always high.

This example shows how a simple button is connected to a digital input.

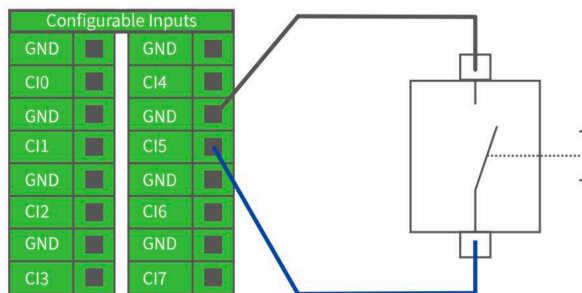

### 3.4.2.2 Controller Digital Output(CO)

The digital output is implemented in the form of NPN. When the digital output is enabled, the corresponding connector will be driven to GND. When the digital output is disabled, the corresponding connector will be open (OC/OD).

The following example shows how to use the digital output, as the internal output is an open-drain (OD) output, so you need to connect the resistor to the power supply according to the load. The resistance and power of the resistor depend on the specific use.

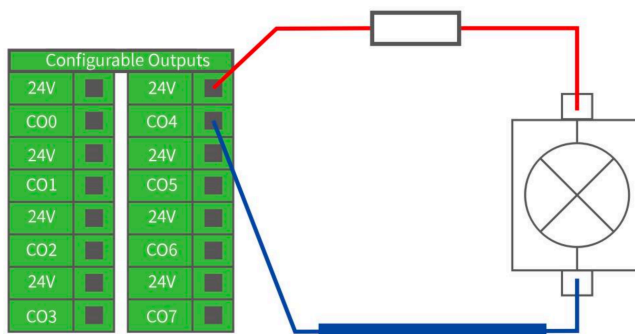

#### Note

It is highly recommended to use a protection diode for inductive loads as shown below.

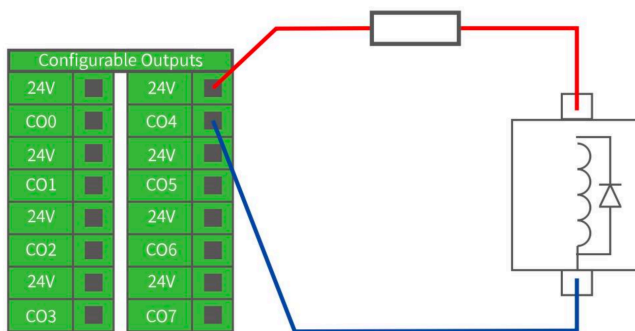

### 3.4.2.3 Communicate with other Machines or PLCs

If general GND (0V) is established and the machine uses open-drain output technology, digital I/O and other can be used device communication, see the figure below.

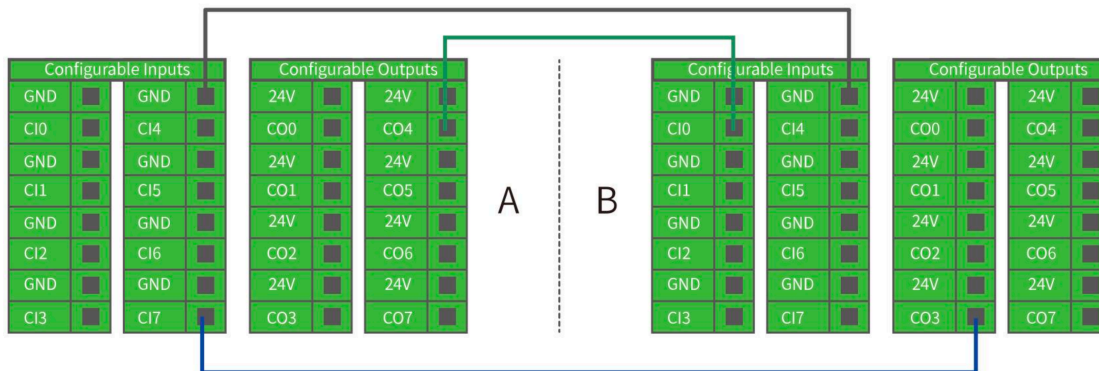

### 3.4.3 Controller Analog IO(AIAO)

This type of interface can be used to set or measure voltage (0-10V) going into or out of other devices.

For the highest accuracy, the following instructions are recommended:

- Use the GND terminal closest to this I/O.
- The device and Control box use the same ground (GND). The analog I/O is not isolated from the control box.
- Use shielded cables or twisted pairs. Connect the shield to the GND terminal on the Power section.

Terminal	Parameter	Min. Value	Typical Value	Max. Value	Unit
Analog Input under Voltage Mode					
[AIx - AG]	Voltage	0	-	10	V
[AIx - AG]	Resistance	-	10K	-	$\Omega$
[AIx - AG]	Resolution	-	12	12	Bit
Analog Output under Voltage Mode					
[AOx - AG]	Voltage	0	-	10	V
[AOx - AG]	Current	0	-	20	mA
[AOx - AG]	Resistance	-	100K	-	$\Omega$

Terminal	Parameter	Min. Value	Typical Value	Max. Value	Unit
[AOx - AG]	Resolution	-	12	-	Bit

### 3.4.3.1 Analog Input

The following example shows how to connect an analog sensor(Connect to AI0 or AI1).

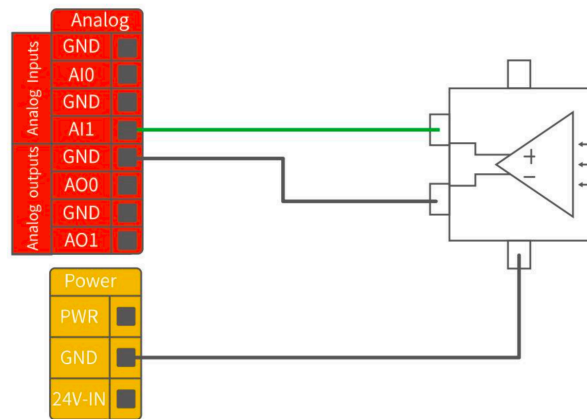

### 3.4.3.2 Analog Output

The following example shows how to use the analog speed control input to control the conveyor belt(Connect to AO0 or AO1).

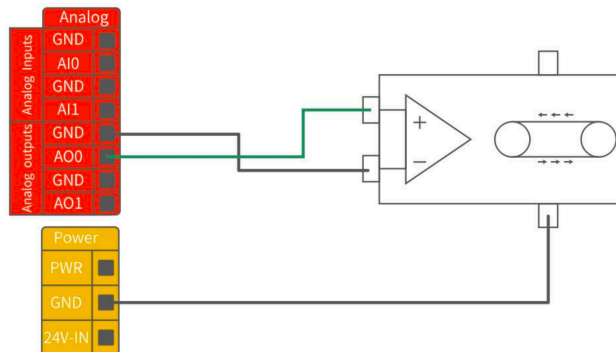

## 3.4.4 Controller RS485

The Controller IO provide an RS485 interface, use can communicate it with third-party devices that supports RS485.

The id of our controller is 10.

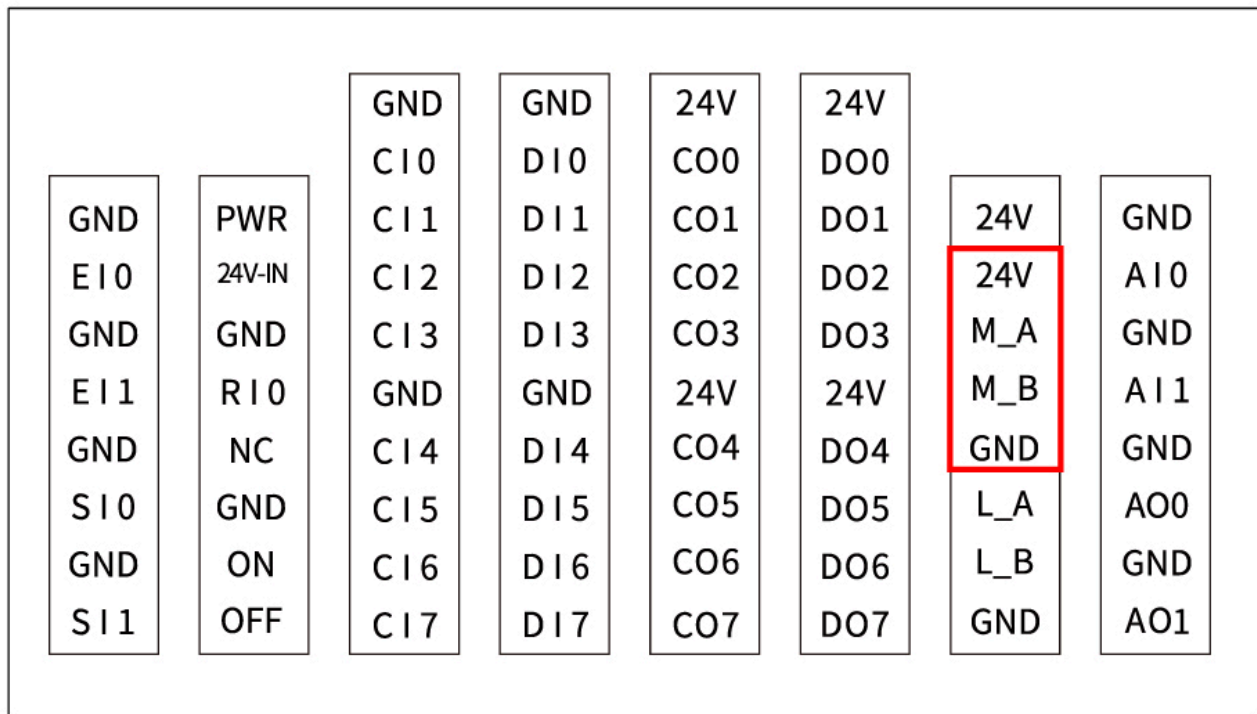

PIN Connection:

1. M\_A (RS485-A)
2. M\_B (RS485-B)
3. 24v
4. GND

#### NOTE

1. L\_A and L\_B are reserved, without functional for now.
2. When using M\_A and M\_B, the robotic arm can only be considered as a master.
3. Support standard Modbus RTU or not.
  - If end effector supports standard Modbus RTU, user can debug it via '[Settings-Externals-Modbus RTU](#)', RS-485 port please choose as 'Control Box'.
  - If end effector doesn't support standard Modbus RTU, user can send the command via [getset\\_tgpio\\_modbus\\_data](#), please set is\_transparent\_transmission to True, the host\_id=10.

### 3.4.5 Reset IP

If you change the IP address, be sure to mark it on the control box. If you forget or lose the modified IP address, you can use the following method to reset the IP.

## Reset IP:

1. Press the emergency stop button and turn off the power of the control box.
2. Connect RIO to GND with a cable.

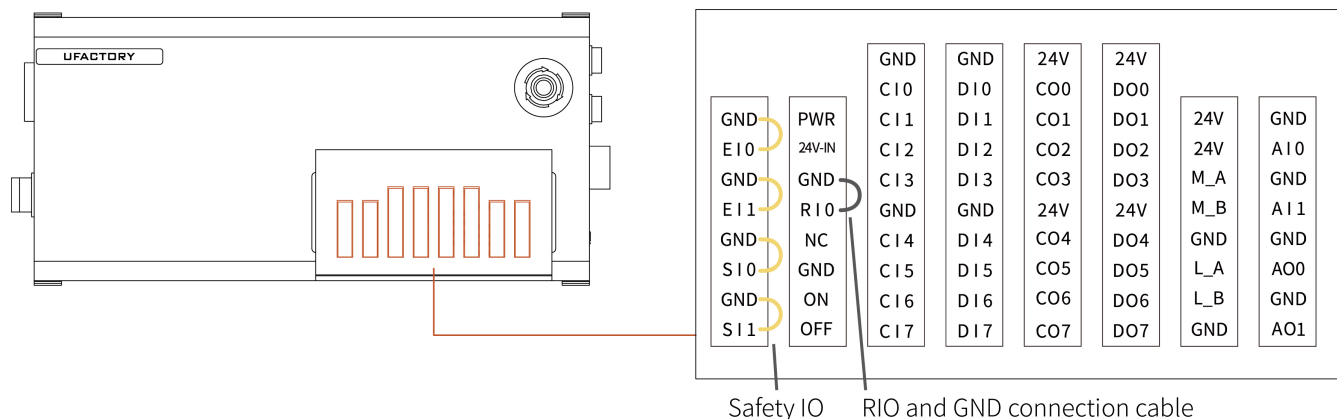

3. Turn on the power of the robot. After hearing the sound of 'beep', it means that the IP address of the robot has been reset successfully. The reset IP is 192.168.1.111.
4. Please unplug the cable connecting RIO and GND and wait for the robot to start up (60 seconds).
5. Enter 192.168.1.111:18333 in the browser to connect the robot.

## 3.4.6 Remote ON/OFF

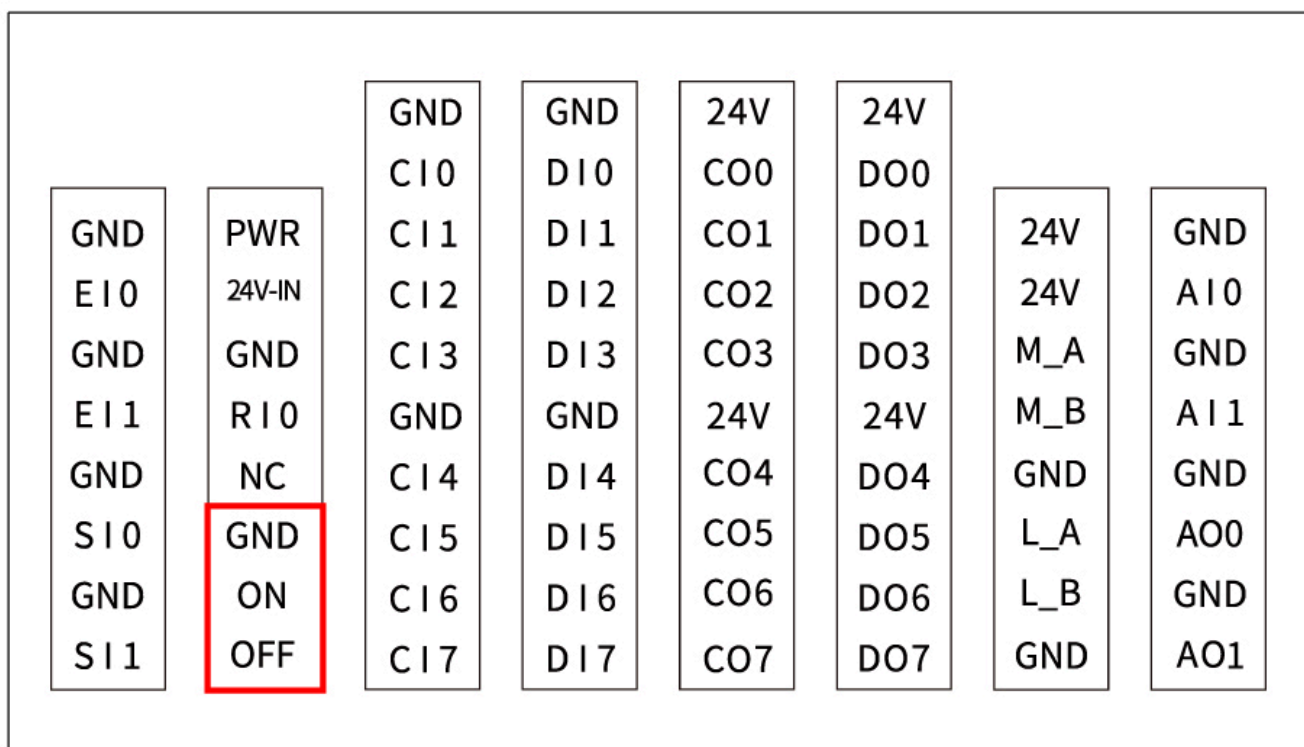

Remote ON: Short ON to GND. Remote OFF: Short ON to GND.

## 4. Robotic Electrical Interface

### 4.1 End Flange

The End-effector flange has 6 M6 threaded holes and one  $\Phi 6$  positioning hole, where the end-effector of two different sizes can be mounted. If the effector does not have a positioning hole, the orientation of the end-effector must be documented in a file format, to avoid errors and unexpected results when re-installing the end-effector.

The end-effector flange referenced ISO 9409-1-50-4-M6 standard.

Mechanical dimensions of end-effector flange (unit: mm)

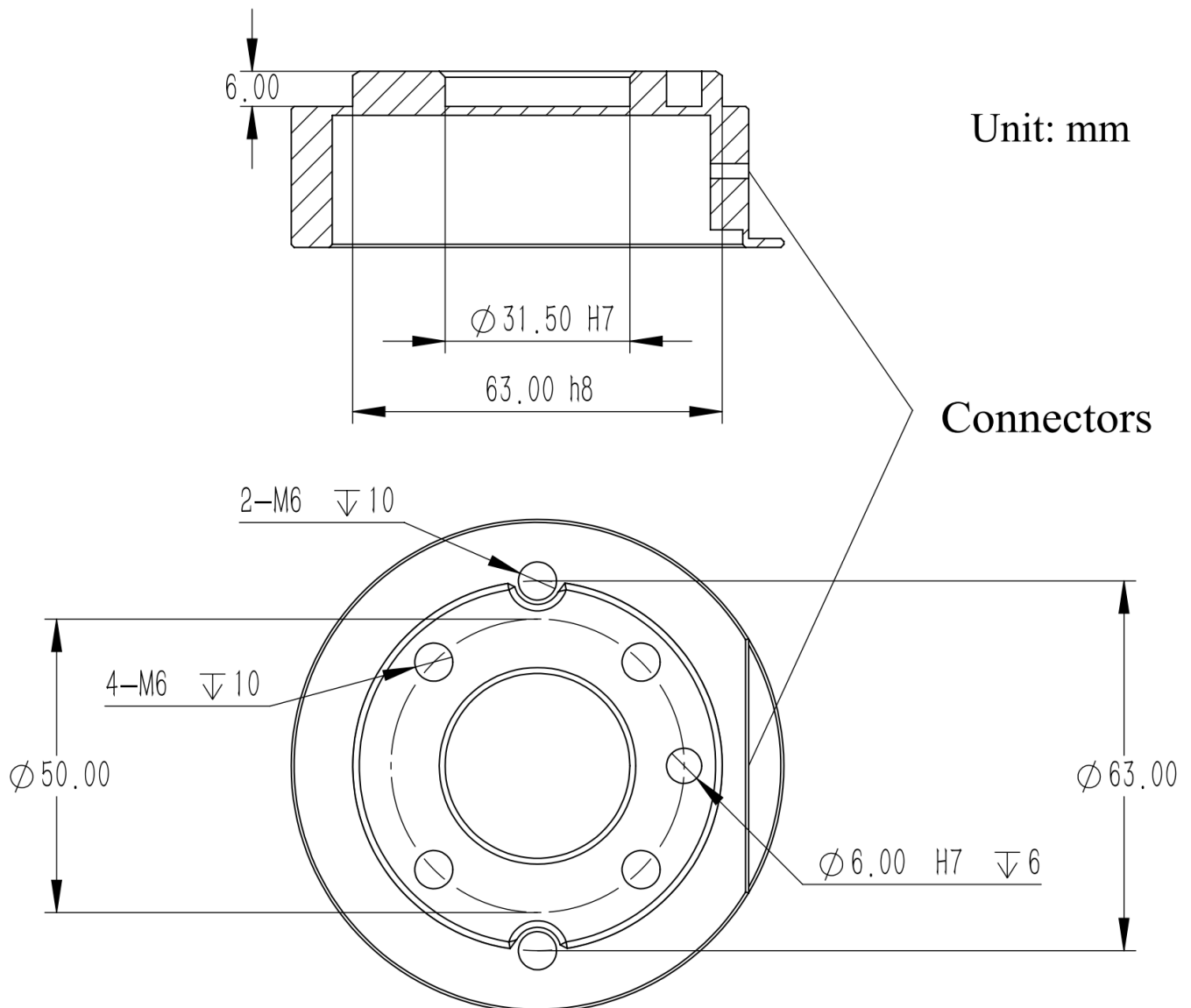

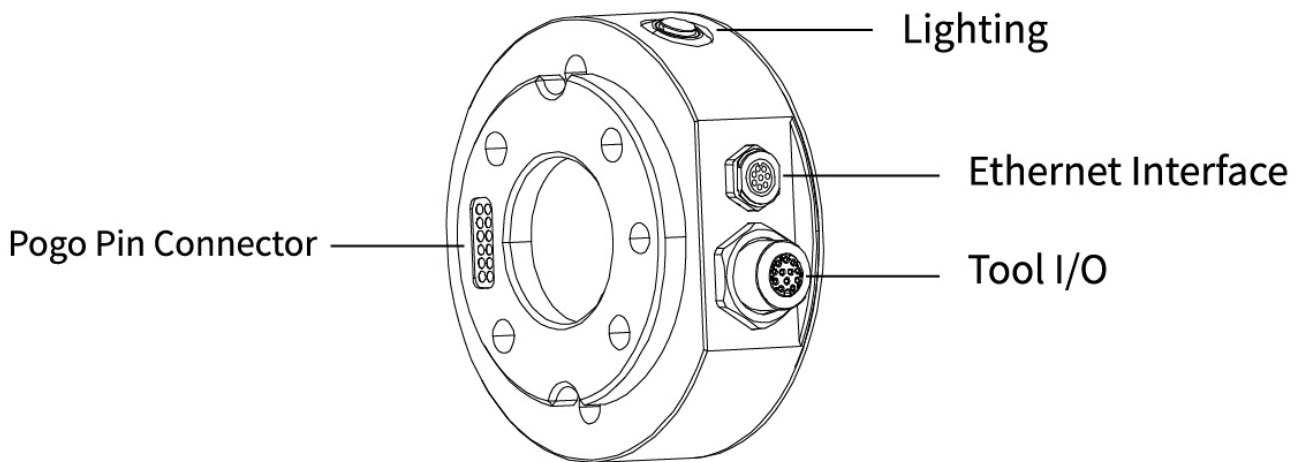

## 4.2 Tool IO

At the tool side of the robotic arm, there is an avionic socket 12-pin female industrial connector. This connector provides power and control signals for the grippers and sensors used on a particular robotic arm tool. Please refer to the figure below:

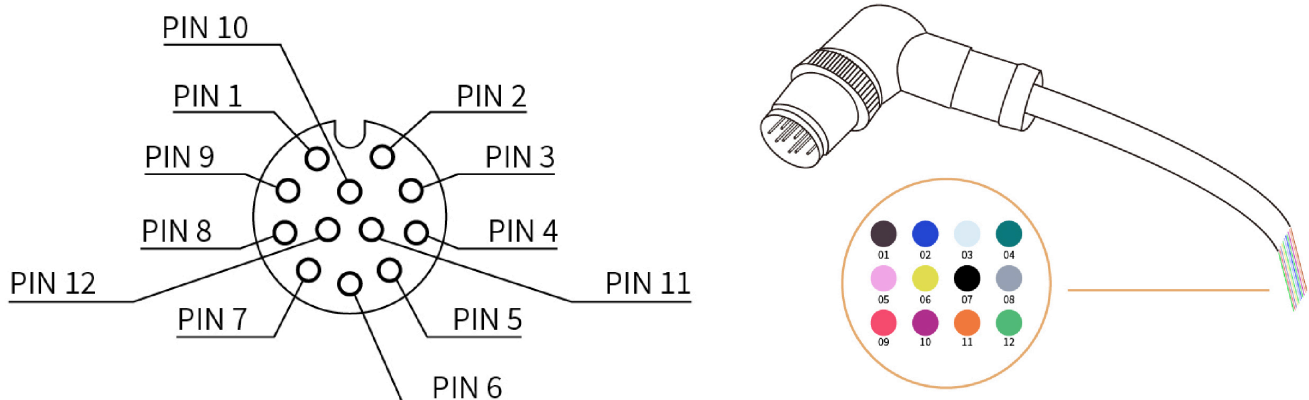

There are 12 pins inside the cable with different colors, each color represents different functions, please refer to the following table:

PIN	Color	Signal	PIN	Color	Signal
1	Brown	+24V (Power)	7	Black	Tool Output 0 (TO0)
2	Blue	+24V (Power)	8	Grey	Tool Output 1 (TO1)
3	White	0V (GND)	9	Red	Tool Input 0 (TI0)

PIN	Color	Signal	PIN	Color	Signal
4	Green	0V (GND)	10	Purple	Tool Input 1 (TI1)
5	Pink	User 485-A	11	Orange	Analog input 0 (AI0)
6	Yellow	User 485-B	12	Light Green	Analog input 1 (AI1)

#### Electrical Specifications:

Parameter	Min. Value	Typical Value	Max. Value	Unit
Supply Voltage in 24V Mode	20	24	30	V
Supply Current	-	-	1800	mA

#### NOTE

It is strongly recommended to use a protection diode for inductive loads.

#### DANGER

Make sure that the connecting tool and the gripper do not cause any danger when the power is cut, such as dropping of the work-piece from the tool.

### 4.2.1 Tool Digital Input(TI)

The digital input is already equipped with a pull-down resistor. This means that the reading of the floating input is always low.

#### Electrical Specifications:

Parameter	Min	Typical	Max	Unit
Input Voltage	-0.5	-	30	V
Logic Low Voltage	-	-	1.0	V
Logic High Voltage	1.6	-	-	V
Input Resistance	-	47k	-	$\Omega$

The following figure shows the connection with the simple switch.

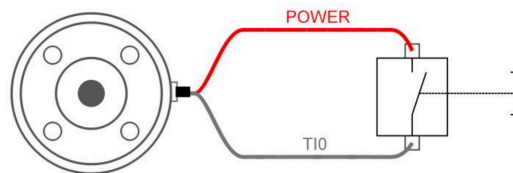

## 4.2.2 Tool Digital Output(TO)

The digital output is implemented in the form of NPN with an open collector (OC). When the digital output is activated, the corresponding connector will be driven to GND. When the digital output is disabled, the corresponding connector will be open (open collector/open drain).

Electrical Specifications:

Parameter	Min	Typical	Max	Unit
Open-circuit Voltage	-0.5	-	30	V
Voltage when sinking 50mA	-	0.05	0.2	V
Sink Current	0	-	100	mA
Current through GND	0	-	100	mA

### CAUTION

There is no current protection on the digital output of the tool, which can cause permanent damage if the specified value exceeded.

The following example illustrates how to use the digital output. As the internal output is an open collector, the resistor should be connected to the power supply according to the load. The size and power of the resistor depend on the specific use.

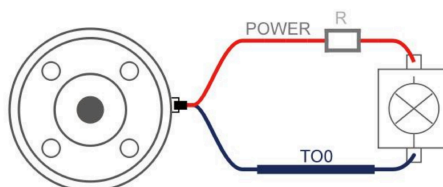

**NOTE** It is highly recommended to use a protection diode for inductive loads as shown below.

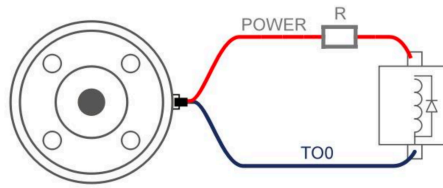

### 4.2.3 Tool Analog Input(TAI)

The tool analog input is a non-differential input.

Electrical Specifications:

Parameter	Min	Typical	Max	Unit
Input Voltage in Voltage Mode	-0.5	-	3.3	V
Resolution	-	12	-	Bit
Input Current in Current Mode	-	-	-	mA
Pull-down Resistors in the 4mA to 20mA Current Range	-	-	165	$\Omega$
Resolution	-	12	-	Bit

#### CAUTION

1. In the current/voltage mode, the analog input does not provide over-voltage protection. Exceeding the limits in the electrical code may result in permanent damage to the input port.
2. In current mode, the pull-down resistance depends on the range of the input current.

The following figures show how the analog sensor can be connected to a **non-differential** output.

- Voltage Mode

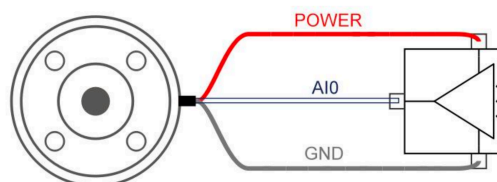

- Current Mode

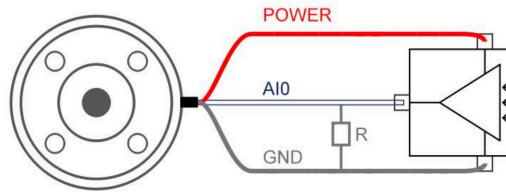

The following figures show how the analog sensor is connected to the differential output. Connect the negative output to GND (0V), and it can work like a non-differential sensor.

- Voltage Mode

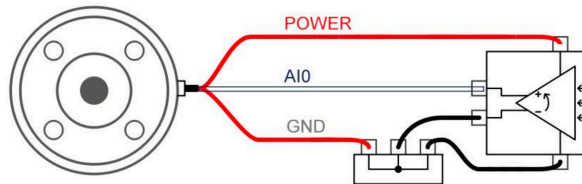

- Current Mode

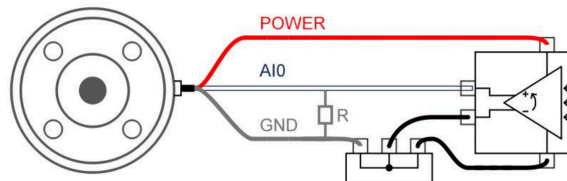

#### 4.4.4 Tool RS485

The Tool side provide an RS485 interface, use can communicate it with third-party devices that supports RS485.

The id of our end tool is 9.

PIN Connection:

1. PIN5: RS485-A
2. PIN6: RS485-B
3. PIN1 & PIN2: 24v
4. PIN3 & PIN4: GND

- If end effector supports standard Modbus RTU, user can debug it via '[Settings-Externals-Modbus RTU](#)'.
- If end effector doesn't support standard Modbus RTU, user can send the command via [getset\\_tgpio\\_modbus\\_data](#), please set is\_transparent\_transmission to True.

## 4.3 Pogo Pin Connector

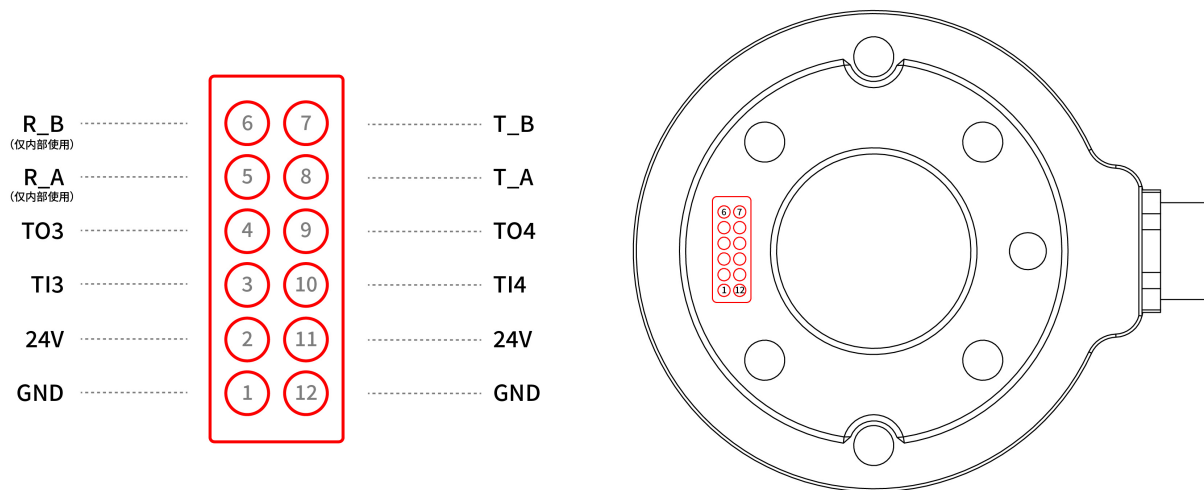

Electrical specifications comply with Tool IO specifications.

## 4.4 Lighting

We provide a button and LED at tool end, press it and it will be Blue.

The function of this button has not been defined yet, user can custom and develop it. Tool Digital IO: TI2, TO2.

```
# SET TO2 to high level, the LED will be Blue.
arm.set_tgpio_digital(ionum=2, value=1)
# GET TI2, for custom develop
arm.get_tgpio_digital(ionum=2)
```

python

## 4.5 Ethernet Interface

The user Ethernet interface(RJ45) of the arm base is connected to the Ethernet interface(M8 4-pole) of the end flange through a physical internal **1000M** Ethernet cable, which further enhances the stability of the system. **Standard CAT5E** Ethernet cable,

compatible with most third-party vision devices. You can experiment with using it as a physical signal wire if you want.

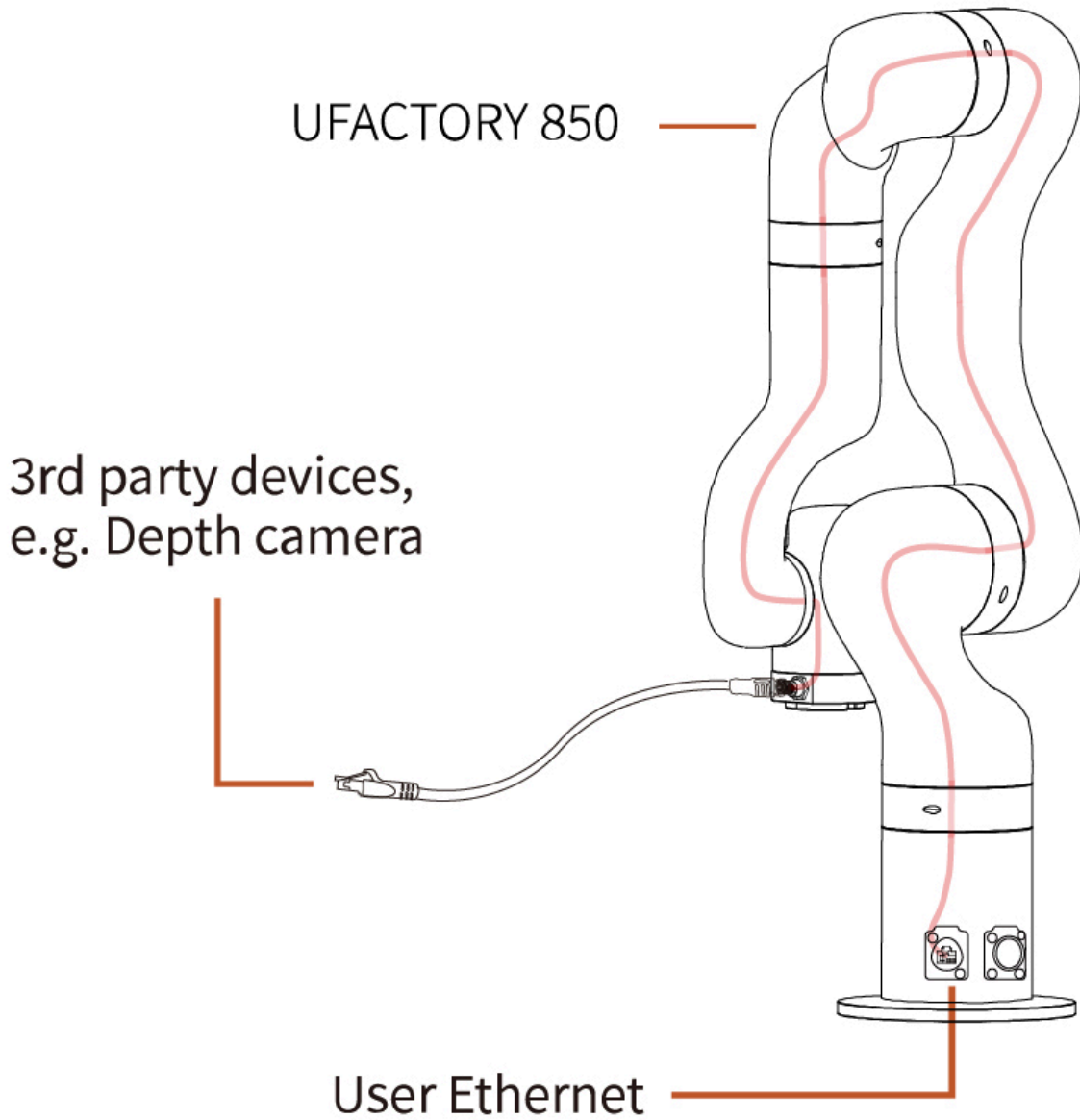

## Definition of Industrial Connector

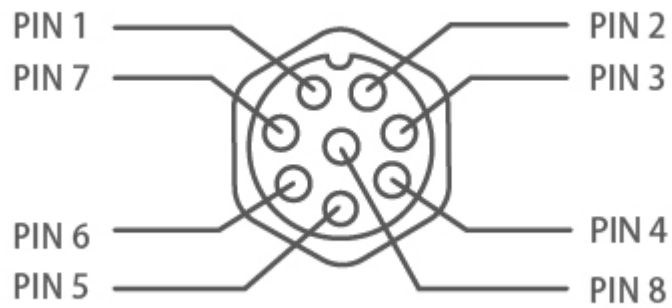

8-Pin Connector			
Pin Sequence	Signal	Pin Sequence	Signal
1	MX2-/DC-	5	MX1+/DB+
2	MX3+/DD+	6	MX0+/DA+
3	MX3-/DD-	7	MX2+/DC+
4	MX0-/DA-	8	MX1-/DB-

## 5. Maintenance and Inspection

1. Long-term placement If the robotic arm is not used for a long time ( $\geq 3$  months), you need to power on the robotic arm for 6 hours every 3 months to charge the built-in battery of the robotic arm. When powering on the robotic arm, please release the emergency stop button on the control box, and the robotic arm does not need to be enabled.
2. Clean  
After the robotic arm is used for a long time, there may be dirt or grease on the carbon fiber shell (in rare cases, a small amount of grease can be seen at the joints, which will not affect the normal use or life of the joints). You can use 95% alcohol or 70% isopropanol to wipe the carbon fiber surface for cleaning.

### Note

When cleaning the carbon fiber surface, be careful not to let the liquid penetrate the joints.

## 6. After Sales Service

1. Repair work must only be done by UFACTORY.

After repair work, checks must be done to ensure the required safety level. Checks must adhere to valid national or regional work safety regulations. The correct functioning of all safety functions shall also be tested

2. After-sales policy: For the detailed after-sales policy of the product, see the official website: <https://www.ufactory.cc/warranty-and-returns/>

3. The general process of after-sales service is:

- Contact UFACTORY technical support ([support@ufactory.cc](mailto:support@ufactory.cc)) to confirm whether the product needs to repair and which part should be sent back to UFACTORY.
- After the bill of lading on UPS, we will send the invoice and label to you by mail. You need to make an appointment with the local UPS and then send the product to us.
- UFACTORY will check the product warranty status according to the after-sales policy.
- Generally, the process takes around 1-2 weeks except for shipment.

### Note

1. Please keep the original packaging materials of the product. When you need to send the product back to get repaired, please pack the product with the original box to protect the product during the transportation.
2. If you need to send the control box to get repaired, please export and save the configuration file([UFACTORY Studio-General-Advanced Settings](#)) of the robotic arm to prevent the original data from being lost or changed during the repair process

## 7. Production Information

---

### 7.1 Product Label

- Robotic Arm



**AC850001A50012**

- Controller



**PRODUCTION DATE:  
Dec. 2024**

**DC850012A40033**

---

### 7.2 EMC(Electromagnetic Compatibility)

- IEC 61000-6-2:2005
  - IEC 61000-6-4/A1:2010
  - EN 61000-6-2:2005 [2004/108/EC]
  - EN 61000-6-4/A1:2011 [2004/108/EC]
-

## Electromagnetic compatibility (EMC)

Part 6-2: Generic standards - Immunity for industrial environments. Part 6-4: Generic standards - Emission standard for industrial environments.

These standards define requirements for the electrical and electromagnetic disturbances. Conforming to these standards ensures that the 850 robots perform well in industrial environments and that they do not disturb other equipment.

- EN 61000-6-4:2019
- EN 61000-6-2:2019

Electrical equipment for measurement, control and laboratory use - EMC requirements. Part 3-1: Immunity requirements for safety-related systems and for equipment intended to perform safety-related functions (functional safety) - General industrial applications.

This standard defines extended EMC immunity requirements for safety-related functions. Conforming to this standard ensures that the safety functions of 850 robots provide safety even if other equipment exceeds the EMC emission limits defined in the IEC 61000 standards.

---

## 7.3 Disposal and Environment

- Low humidity (25%-85% non-condensing)
  - Altitude: <2000m
  - Ambient temperature: 0°C ~ 50°C
  - Avoid direct sunlight (indoor use)
  - No corrosive gas or liquid.
  - No flammable materials.
  - No oil mists.
  - No salt sprays.
  - No dust or metal powder.
  - No mechanical shock, vibration.
  - No electromagnetic noise.
  - No radioactive materials.
-

## 7.4 Transportation

- Move the robot to the zero position by UFactory studio, then put the 850 robot and Control Box in the original packaging.
  - Transport the robot in the original packaging.
  - Lift both tubes of the robot arm at the same time when moving it from the packaging to the installation place. Hold the robot in place until all mounting bolts are securely tightened at the base of the robot.
  - The controller box shall be lifted by the handle.
  - Save the packaging material in a dry place, you may need to pack down and move the robot in the future.
- 

## 7.5 Controller Placement Height

The controller should be placed at a height of 0.6m to 1.5m.

---

## 7.6 Power Supply

The power cut-off method of this product is a plug/socket connection, so when using this product, it is recommended to equip with a suitable switching device with sufficient breaking capacity (such as an air switch; insulation voltage: 400V AC; rated current: 10A)

---

## 7.7 Special Consumables

Fuse Specifications: 15A 250V 5×20mm Time-Lag glass body cartridge fuse.

---

## 7.8 Stop Categories

**Stop Category 1** and **Stop Category 2** decelerates the robot with drive power on, which enables the robot to stop without deviating from its current path.

---

Safety Input	Description
Emergency Stop Button of the Control Box	Stop Category 1
Emergency Input of the Control Box(EI)	Stop Category 1
Safeguard Stop of Control Box(SI)	Stop Category 2

## 7.9 Stop Time and Stop Distance

Stop Category 1 stopping distances and times.

The table below includes the stopping distances and times measured when a Stop Category 1 is triggered. These measurements correspond to the following configuration of the robot:

- Extension: 100% (the robot arm is fully extended horizontally).
- Speed: 100% (the general speed of the robot is set to 100% and the movement is performed at a joint speed of 180 °/s).
- Payload: maximum payload handled by the robot attached to the TCP (5 kg).

The test on the Joint 1 was carried out by performing a horizontal movement, the axis of rotation was perpendicular to the ground. During the tests for Joint 2 and 3 the robot followed a vertical trajectory, i.e. the axes of rotation were parallel to the ground, and the stop was performed while the robot was moving downwards.

	Stop Distance(rad)	Stop Time(ms)
Joint1	0.62	521
Joint2	1.12	885
Joint3	0.67	577

## 7.10 Certification

[DSS\\_MD-GZES2403005468MD.pdf](#)

[DSS\\_GZEM2403001755MDVR.pdf](#)

---

## 7.11 DH Parameters

[DH Parameters](#)

---

## 8. Technical Specifications

UFACTORY 850	
Robot Type	UFACTORY 850
Robot Weight	20KG(body only)
Maximum Payload	5kg
Cartesian Range	X: $\pm 850\text{mm}$ , Y: $\pm 850\text{mm}$ , Z: $-400\sim 1214\text{mm}$ , Roll/Pitch/Yaw: $\pm 180^\circ$
Joint Range	J1~J6 ( $\pm 360^\circ$ , $\pm 132^\circ$ , $-242\sim 3.5^\circ$ , $\pm 360^\circ$ , $\pm 124^\circ$ , $\pm 360^\circ$ )
Maximum Speed of End-Effector	1m/s
Maximum Joint Speed	180°/s
Repeatability	$\pm 0.02\text{mm}$
Ambient Temperature Range	0-50°C
Power Consumption	Typical 240W, Max 1000W, 500W Power is recommended.
Input Power Supply	48V DC, 20.8A
ISO Class Cleanroom	5
Mounting Way	Any Direction
Materials	Aluminium, Carbon Fiber
Footprint	$\varnothing 190\text{mm}$
End Flange	DIN ISO 9409-1-50-4-M6 (M6*6)
Robotic Arm Communication Protocol	Private TCP(custom)

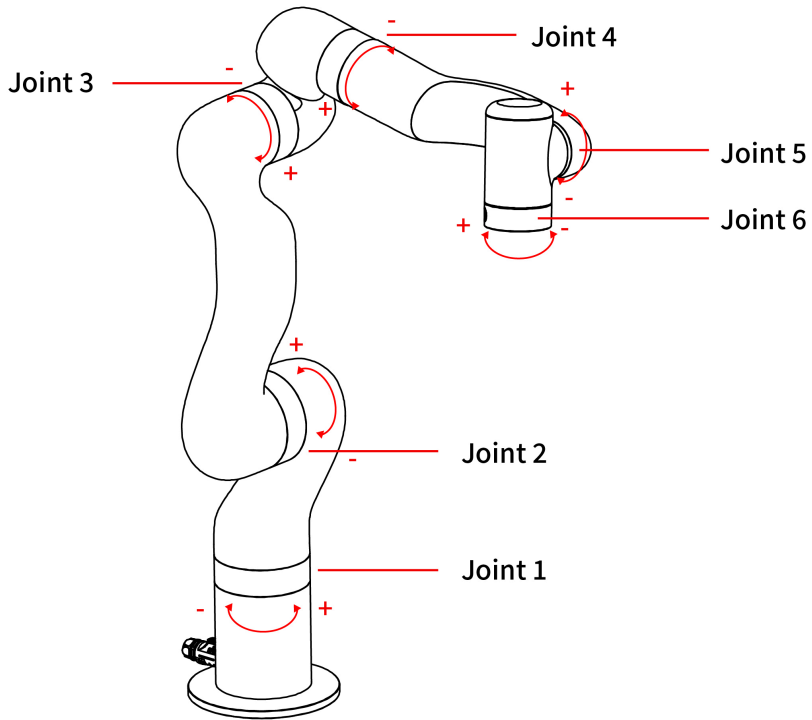
<b>UFACTORY 850</b>	
End Effector Communication Protocol	Modbus TCP
Programming	UFACTORY Studio, Python/C++/ROS
Joint Rotating Direction	

	AC Controller	DC Controller
Input	100-240V AC 50/60 Hz	48-72V DC
Output	48V DC 1000Wmax	48V DC 960Wmax
Communication Protocol	Private TCP(custom)	Private TCP(custom)
Communication Method	Ethernet	Ethernet
I/O Interface	8×CI+8×DI(Digital In) 8×CO+8×DO(Digital Out) 2×AI(Analog In) 2×AO(Analog Out) 1×RS-485 Master	8×CI+8×DI(Digital In) 8×CO+8×DO(Digital Out) 2×AI(Analog In) 2×AO(Analog Out) 1×RS-485 Master

	AC Controller	DC Controller
Weight	4.8kg	2.8kg
Dimension(L×W×H)	345×135×101mm	262×160×76mm

Gripper G2(AG1200)			
Nominal Supply Voltage	24V DC	Absolute Maximum Supply Voltage	28V DC
Quiescent Power (Minimum Power Consumption)	1W	Payload	5kg
Weight	800g	Clamping Force	10-50N
Working Range	84±1mm	Speed	15-225mm/s
Finger Type	Replaceable	Cycle Life	>2,000,000 cycles
Communication Method	RS485	Communication Protocol	Modbus RTU
Programmable Gripping Parameters	Position, Speed, Force	Feedback	Position
Protection Rating	IP40	Operating Temperature	50°C

Vacuum Gripper(AS1200)			
Rated Supply Voltage	24V DC	Absolute Maximum Supply Voltage	28V DC
Vacuum	-55kPa	Vacuum Flow (L/min)	> 4L/min
Weight	610g	Dimensions (L×W×H)	122.5×91.6×75 mm
Payload	≤5kg	Noise Level(30cm away)	< 60dB
Quiescent Current(mA)	20mA	Peak Current(mA)	500mA

<b>Vacuum Gripper(AS1200)</b>			
Communication Mode	Digital IO	State Indicator	Power State, Working State
Feedback	Air Pressure(Low or Normal)		